

THE DO-IT-YOURSELF OCCUPATION GUIDE



2012 *Redux*

INTRODUCTION

We can no longer simply protest to demonstrate our rage; decades of activism have come to the point of an impasse. To fight for single issues without addressing the state and capitalism in its entirety will not be able to make the transformations we wish to see possible. Politics turns our lived experiences into useless abstractions and uses those abstractions to fuel meaningless ideological battles. It is time to bow out of the theater of politics.

Instead, we must insist on the struggle for the satisfaction of immediate needs and desires. In other words, the seizing of buildings for shelter, the organized looting of sustenance for our bodies and minds, and the cultivation of new ways of living and providing for one another so as to sustain our attack against the structures that impoverish our lives. At this moment, in relation to the horizon of the gradual generalization of building occupations, we must pose a question: *what would it mean to begin a broader project of expropriation?*

Recently, the discussion of private property has limited itself to vandalism; it has been mired in circular conversations about “violence vs. nonviolence.” We wish to bypass this debate by naming what this sup-

posed violence is perpetrated against: *the meaning of private property as a social and material relation.*

We look ahead to when we enter the buildings, take over the streets, and occupy the city. To do this we need to further cultivate the various techniques of occupation that have been put on the table for building takeovers. That is the goal of this manual. We need to sharpen our practice until it is possible to defend a space indefinitely. This is not just a question of material means and capacity. Equally, it is a question of social strength and the development of a certain spirit.

Attempts to occupy abandoned buildings have multiplied across the States in a matter of months. There were several occupations across the country in November and December of 2011, ranging from the Traveler's Aid building and two vacant lots in Oakland; a car dealership in Chapel Hill, North Carolina; a vacant warehouse in Seattle; and an empty bank in Santa Cruz. Lessons drawn from these were influential upon the organizational structure of the J28 occupation attempt in Oakland. All of these attempts informed the contents of this document, although our immediate experiences were in Santa Cruz and Oakland.

The Wave of Winter Occupations

The Traveler's Aid building in Oakland was taken on November 2nd, the night of the General Strike. The building was a political target, formerly occupied by a non-profit organization that provided homeless services and had gone bankrupt due to budget cuts. It sat vacant just a block from Oscar Grant Plaza. The beginning of the occupation was timed to coincide with the return of a march from the Port of Oakland. Once the building was open, people went inside and began decorating their new social center. When the cops arrived, people spilled out onto the streets; leaving the building empty once again. Burning barricades were put on the street to deter the pigs but after a few hours of fighting, the building was reclaimed by the city. Because many people were not clear on their role in relation to the occupation and additionally, the time in the building being relatively short-lived, many people did not develop an investment over the

space or, perhaps more importantly, over the *potential of the space*.

The 75 River Street occupation was an occupation of an empty bank in Santa Cruz that lasted four days and three nights. On the first day, the police were successfully repelled by the strength of the barricades inside the building and the size of the ferocious crowd outside. After the police left, there were many discussions about what to do in the space. In the end, after much anxiety about eviction and repression, people chose to leave. One lesson learned from this occupation attempt was to have activities (such as workshops on barricade construction, film showing about other occupation struggles, radical history classes, etc.) to further possibilities within the liberated space, as opposed to continually fretting about eviction.

Occupation: Theory and History

The #Occupy movement has become known for its particular use of the tactic of occupation, re-introduced in the United States during the student movement in NYC and California from 2008 to 2009. The series of occupations lasted for several months, in which the tactic was put forward in relation to the idea of “demandlessness,” to have no demands aimed toward or dialogue with those supposedly “in power.” Historically, the tactic of occupation has been utilized as political leverage in order to satisfy demands, a means to an end. The student occupations, particularly in California, attempted to shift the content of the tactic of occupation, to make the act of occupation an end-in-itself without the need for political demands but for the generalization of the occupations. These occupations helped articulate what it might mean for an occupation to exist as an end in itself, instead of as a technique of leverage for the fulfillment of political demands.

Notes on Us and Them

∞ This “we” and “our” is generated through struggles and does not refer to a pre-determined scene or milieu.

∞ We must be careful with “us versus them” logic, which oftentimes lapses into the logic of demanding some thing from “them” (those in power). While there are still social and class enemies, we must remember that our power to accomplish whatever project depends ultimately on an “us” and not a “them.”

With the advent of the #Occupy movement, the content of the occupations echoed the occupations of the student movement. Initially, it was a site to air out grievances and indignation against prevailing economic disparities - its targets were corporations, banks and politicians. This began to stand in sharp contrast to *what the camp was actually doing*. The camp provided a new meaning to occupation. No longer just a political means, the camp materially demonstrated that we could provide for ourselves and, more importantly, learn how to live and fight together.

Occupations can last anywhere from a few hours to a few months. While the occupation of a space may be used to satisfy social or political demands (we are taking their buildings hostage after all), we are beginning to see the utility and practicality of occupation as an end-in-itself.

PRACTICAL TECHNIQUES

The following techniques are meant to provide a basic guideline for initiating an occupation. These techniques come from a combination of research and personal experience and are by no means the only ways of doing these things. Suit them to your own circumstances, adapt them to your particular strengths, re-invent them based on your own experience.

Obviously, seizing space requires individuals with skills and supplies. To prevent occupation from becoming a specialized activity, those with skills and supplies need to simultaneously sharpen their own practice and disseminate the techniques and spirit necessary to occupy space.

Reconnaissance

The imagined content of an occupied space is the foundation that will determine its shape and location. Is it a clandestine occupation in a neighborhood, used for meetings and organizing? Or is it a commercial space in a downtown area, used for large events and assemblies?

An overgrown yard, old mail in the mailbox, a garbage can full of old garbage or empty or nonexistent, old fliers on the door, holes in the roof, lots of “no trespassing” signs, obvious fire damage, “for sale/lease/rent” signs, soaped or boarded or papered windows--none of these alone are proof that a house is unoccupied, but they are all signs that it might be.

Look for signs of an alarm system. If it is advantageous to disable the remote alarm, determine where the phone line enters the house (the phone lines are often the lowest on overhead lines). Note the presence of remote or local alarms (more information in the “alarms” section).

Tax records for a property are available through the county. If all the taxes are paid, then the owner probably cares about the property and is hoping to sell it. If there is a large amount of unpaid taxes, the owner might be absent or disinterested in the property. At the recorder’s office, one can find all the records attached to a property, such as whether a property has been foreclosed upon.

After scouting locations in the daytime, come back at night to investigate potential entry strategies. Try every angle. If you are worried that you have tripped a silent remote alarm, leave the space and come back later. It is sometimes worth waiting nearby to see if there is an immediate response, but be aware of the risks of loitering nearby, potentially with tools in your possession.

Alarms

The specifics of alarm systems and their circumvention is too broad a topic to discuss here, but understanding some basics could contribute greatly to the

success of the occupation. For this immediate purpose, we will classify alarms into two types: *local and remote*.

In preparation for an occupation, the two types of alarms necessitate two separate approaches. In the early stages of scouting, determine if local alarms are present (look for external loudspeakers, bell boxes). Finding the location of local alarms and being prepared for their removal are important steps in the initial scouting of a building.

Local alarms include sirens, bells or lights mounted on the building itself. If a local alarm is tripped, the effect is immediately known. Sometimes, the lights or audible alarms will be on a delay so that it appears as if someone has been alerted to your presence and turned the alarm on.

When triggered, remote alarms transmit to someone somewhere else – usually private security but sometimes the police – that the building has been entered. In almost all residential properties and most commercial properties, this signal is transmitted through the existing phone line. In particularly sensitive buildings (banks, jewelry stores, etc.), a separate phone line will be dedicated for this purpose. Beyond signals transmitted over phone lines, wireless monitoring of alarm systems (usually through cell phone networks) is rapidly proliferating.

Assume that remote alarms are present. Remote alarms cannot simply be cut out of the wall. Tampering with alarms usually trips them. It is also not an option to cut the power--they are usually hardwired into the power grid or run on batteries. Remote alarms have one weakness--the phone lines over which they travel. For remote alarms that use the existing phone line, cut the phone line where it comes into the Telephone Interchange box. This will prevent the signal from being transmitted to the police or security firm. Dedicated lines or wireless monitoring are much harder to disconnect.

During an occupation, remote alarms can often be safely ignored. If a building isn't opened until some large public action, the police are probably already following that action. The utility of disabling remote alarms is that it allows clandestine entry to the building, possibly to prepare for its public opening.

Local alarms are much harder to ignore. During an occupation, it would be useful to bring the equipment necessary to access the alarms, towels or foam padding to stuff around the alarm, and insulated wire cutters to cut the power to the alarm.

Entry

There is always a way to enter any building. Entry to a building should

always be obtained with the least destructive means possible; the best entries are always the clever ones. Before you bring out the bolt cutters and angle grinders, walk around the building and investigate every possible way in. Cleverness is more discreet, and less obviously illegal, than brute force.

Many foreclosed houses and even some commercial buildings that are actively being shown leave the keys in a lockbox somewhere on the property. The cheaper lock boxes are easily removed and opened. Almost all commercial buildings keep a set of keys in a high-security "knox box" on the building. The more expensive ones are often more work than they are worth, but should still be considered as an option. Often, an identical lockbox can be rehung with the original keys -- after copies have been made and the original combination reset -- thus disguising any tampering. If a lockbox is present, research the particular type to see if it can be replaced and the combination reset.

If someone you know has locksmithing experience, attempt to pick a set of locks to gain entry.

Pushbar doors can be opened from the outside using a bent piece of thin metal to push the bar (by code, the push bars have to open with only 15 pounds of force).

GETTING TO THE SPACE

There are several ways to bring a mass of bodies to a building. How this happens depends on whether the location of the building is initially a secret known only to a few people, or is already publicly known. This also depends on whether the occupation will be initially open or closed (see sidebar in “defense”).

Setting up a march. Select a convergence point where there will be a rally, from where the march can begin. In deciding how to get to the space, select several alternative routes in addition to the primary route. Much of the actual decision-making may have to be made on the ground, while the march is en-route to the site. Form a tactical group to decide upon the logistics of the march – several scouts pre-empting

police maneuvers, individuals within the crowd of people directing the march, individuals ready to open up the space, and so forth.

You may need to set up several teams for the day of the action, coordinating with one another in order to keep the march tight and to keep people who don't know about the location together. Talking through the action with others before the big day may help towards mental preparation. The central question may revolve around what to do about police presence and an alternative plan in case of a heavy police presence. How will the march be defended against possible police attacks? How will the march be guided? By what means will the march be coordinated?

SUPPORT

All of these (and probably more) support structures are necessary if the occupation is a success. Many are still necessary if the attempt is a failure.

Legal Support

Contact a lawyer. Some lawyers are willing to provide free legal support. Get in contact with lawyers before the action. Have someone stationed at a landline, if and when people need jail support. All occupiers should write the jail-support phone number on their body with a sharpie or marker.

Know your rights. Do not say anything to police except your name and that you will not speak until your lawyer is present. A good reference is Katya Komisaruk's book *Beat the Heat*.

Resisting arrest. If a police officer stops you, ask if you are being detained. If you are not being detained, walk away. If you are arrested, it is your decision whether to resist or not, but take into consideration that it will raise your charges. If you have a chance, run the fuck away.

Jail support. If comrades get arrested, be ready with money for bail or bond. As comrades are processed and released from jail, be there to receive them (with friends, coffee, cigarettes, etc.) When people have court dates, go to them in large groups.

Medical Support

Medics. Have medics both inside and outside the building. Medics should

know about the needs of specific individuals involved in the action beforehand (medications, allergies, etc.). They should have a first aid kit. Anybody can be a street medic, but make attempts to contact RNs and EMTs.

Pepper spray. Clean out eyes with a mixture of milk of magnesia and water.

Tear gas. Have several rags soaked in vinegar, which is helpful to lessen the impact of the gas when inhaled. Also use eye protection and/or a gas mask.

Rubber bullet injuries. Prepare to clean and suture wounds from rubber bullets for comrades who cannot be taken to the hospital.

Propaganda Team

Press releases. Have an initial statement prepared before the occupation is announced. Pour out your rage, but make sure you also provide a reasonable explanation for what you are doing, since many people will want to know why you did it. Do not have an official line. Do not prevent people from expressing themselves in their own way. Have people on hand to make and distribute flyers about what you are doing when the occupation takes place.

Media team. Designate one or more people as media contacts on the outside of the occupation. Remember

to emphasize the media people as delegates, not representatives of the occupation. Alternative media such as Indybay allows for self-publication of events. Set up an email address and website associated with the occupation (remember to disguise your IP and MAC addresses). Make this information easily available. Do not use the personal email address of anyone involved in the action.

Media relations for those inside. No particular individuals inside the occupation should become too visible, so as not to be branded as leaders. No one on the inside should give televised interviews, or any more information about themselves than necessary.

Other Considerations

Emergency Text System. Collect phone numbers to set up an emergency mass text-message system in case of a police raid.

Police Liason. There are ups and downs to having a police liaison. You can decide for yourself whether having one is useful. It is important, however, that the police liaison is not known to be a member of the occupation. Because they are interacting with the enemy, police liasons are often more vulnerable to arrest and harassment.

Supplies. It is possible that you will be removed in the first few hours. Do

not over-pack. Bring some food and water (that is, if you have no access to running water), and medical supplies. Pack extra locks, cables, etc. in case you need them. Be careful with the content of your computer – it shouldn't contain anything you wouldn't want the police to see in case it gets confiscated. If you are successful, people can bring you extra supplies: food, cigarettes, blankets, etc.

Pack a Go-bag

Before the day of an occupation, pack a bag with everything you will need for that day. Make sure everything is replaceable - it may be confiscated or lost. Bring things to be safe in the streets (change of clothes, face covering, paint bombs, gloves, goggles, medical supplies, water, snacks, etc.). Also be prepared to carry supplies for the occupation (truck tie-downs, locks, arm-chairs, chain, etc.). Remember to bring enough to share with your comrades.



Tradespeople. Have skilled or experienced individuals ready to set up the infrastructure for the occupied building, or ready to turn on utilities that have been turned off by the city, etc.

Share everything. Inside the occupa-

tion, there is no private property.

Break down barriers. Inside, social status and jobs are meaningless.

Use the building as an organizing space. Now that it's ours, it can be a launch pad for more occupations and other actions. It can become a focal point for the enraged and disaffected. Invite members of your community who are being fucked over to come in and help build the struggle.

Vandalism? Occupying a space removes the space from the capitalist landscape. A group may decide it is better to destroy or vandalize a space than to return it to its usual role in good condition. The role of vandalism may be different in each situation, but it should not be disowned outright.

DEFENSE

The defense of the space cannot be reduced to any one particular factor. The successful defense of an occupation is a mixture of social, political, material and symbolic aspects of the conditions for action, in which one factor may hold significance over the others.

Social. In the sense that popular support oftentimes prevents the city government from deploying the police immediately.

Political. The occupation's antagonism must be made clear (the enemy must be clearly named).

Material. Barricades on the doors and in the streets, shields and flags for street defense, a sound system for mo-

rale, supplies to maintain and thrive in the space.

Symbolic. The significance of the occupation can extend far beyond its immediate circumstances.

* * *

In order to further develop and coordinate our movement on the streets, we could begin compiling intelligence on police maneuvers and tactics against crowds. What are basic formations the police use against large crowds? What arsenal is at the police's disposal and how can we prepare to defend ourselves against police offensives? What codes and signals do they use so as to coordinate their actions against us? How can we coordinate ourselves

in relation to the cops' maneuvers and attacks? When the cops either prevent us from taking a space or kick us out, how should we respond?

Know Your Enemy

- ∞ Lines of police will pen a crowd in an intersection or will push into a crowd to divide it in half. A series of police charges can be used to slowly push the crowd down a street.
- ∞ Penned crowds will be attacked with batons or chemical weapons to lower morale.
- ∞ Crowds throwing projectiles will be 'put to flight.' It's harder to throw stuff if you are running.
- ∞ Police morale will be lowest right before a shift change. Shifts slightly overlap, making shift changes look like the arrival of reinforcements.

Defense Tips

- ∞ Keep looking outward. For example, if someone is being given first aid, stand and face away from them.
- ∞ Form cordons as much as possible. Anything the police want, including buildings and especially sound systems needs a strong outwardly facing cordon. Try to find ways to make barriers either with your bodies or with various objects.
- ∞ Someone needs to watch the police from a good vantage point, so that their next moves can be preempted.
- ∞ The best barricades are random material strewn all over the place – police find it hard to hold a line, but individuals can easily pick their way through. If police are advancing from only one direction and you have clear escape routes behind, barricade.

Black Bloc

The black bloc tactic came into existence in Germany in the 1980s as a response to heavy police repression. At the time, criminalized youth put their lives in common and constructed a way of living to sustain themselves apart from capital and the state. Their project, containing both antagonism and social/material self-support, was to take over parts of the city. The expropriations of space multiplied across the city and police offensives responded reciprocally. The black bloc tactic was formulated as a response to police attacks on comrades, a response that was self-justified as an act of retribution. It allowed large groups to act together more anonymously. The black blocs attacked the symbols of alienation and oppression – shopping districts, luxury cars and gentrified neighborhoods – to materialize solidarity.

∞ Disguising individual identity (with tactics like black bloc) helps keep everybody safer. People entering the building or defending the march should disguise their identities; other participants should do the same to give the entry and tactical crews more cover.

∞ The best form of defense is disorder. Keep moving all the time. Change your appearance. Open up new directions and possibilities; be unpredictable.

Defending the March

Use shields and reinforced banners to defend the march against the police.

Before the march, talk to a group of your friends about what you can offer to the defense of the march, materially or tactically. Maybe your crew can make shields or paint bombs to share, bring masks and hoodies to help others protect their identities.

During the march, coordinate with other crews to help make the occupation happen. Defend the march against the police as you see fit. Use your crew's strength to reinforce larger tactical decisions.

Defending Against Eviction

On the initial day of the 75 River occupation in Santa Cruz, the police

were successfully repelled by a combination of barricades inside the building and a large crowd outside. The police were pinned by a hostile crowd to a building that they were unable to enter. They left after a brief stand-off.

The three zones of defense proposed by the Oakland Move-In Assembly expands upon this model. See the sidebar in the J28 section for a full explanation of Occupy Oakland's eviction plan.

Eviction defense strategies are widely variable. An understanding of your own material capacity and social strength, a knowledge of police operations, and a forecast for the political climate are all important parts of a successful defense.

Closed vs. Open Occupations

Closed occupation. A closed occupation says "we aren't leaving until you drag us out." Barricade the windows and doors and have a stockpile of essential items. Most often, an open occupation will close to weather an eviction attempt.

Open occupation. Open occupations will allow people to enter and leave the occupation, usually through a single entrance. All the other entrances are reinforced. Prepare to reinforce the open entrance when the police arrive.

Or, a group of people might move into a vacant building in an unprovocative way, set it up, and see what happens.

REFLECTIONS ON J28 MOVE-IN DAY

Often buildings are opened up in secret, without predetermined content. In contrast, the open organizing structure of the J28 Move-In Day enabled many people's involvement and utilized the momentum of Occupy Oakland. The day saw 1000 to 2000 people flood the streets to illegally take over a building to create a permanent social center for Occupy Oakland.

The Plan

The plan was to take over the Kaiser building, the largest, oldest, and fanciest public auditorium in downtown Oakland, and set up a permanent social center. On the weekend the building was to be occupied, there was to be a two-day festival with music and guest speakers. Supplies were gathered

to serve as decoration and barricades. A tactical team was designated to coordinate the march and gain entry into the building. The day of the march, the group was to make decisions on-the-fly, synthesizing information about the status of the march, the viability of alternate locations, and the movements of police as reported by scouts throughout the city.

After gaining entry to the Kaiser building, the infrastructure would be set up within the building, divvying up the space and subsequently the festival would begin. The tactical team would dissolve itself and be replaced by the building committee, which would organize activities and projects within the space. In the event of a police intervention, the zones of defense

would come into play as a coordinated response by occupiers (see sidebar below).

Organizational Structure

Because people were not clear on their role in the Traveler's Aid occupation and the time in the building was short, many people didn't develop attachment to the potential of the space. Learning from these past mistakes, organizers of J28 wanted to ensure widespread participation and allow time to develop investment in the idea of a social center.

For these reasons, the move-in day proposal was brought before the GA. The proposal called for a clandestine

tactical team to work on the logistics of the building. To build trust in this secretive structure, this group was comprised of at least one person from each committee within Occupy Oakland. The members of this committee knew the location and mode of entry into the building. The proposal included a list of parameters for the type of building to be taken:

needed to be owned by a corporation or governmental entity rather than an individual;

large enough to fit Occupy Oakland assemblies and committees;

has water and power;

Zones of Defense - Occupy Oakland Eviction Defense Strategy

The "zones of defense" plan would have been implemented to ensure maximum participation and encourage people with varying comfort levels around the police, legal standing, or ethical positions to participate in taking and defending the building.

The *first zone* – thought to be the safest – was to be people inside the building.

The *second zone* would be directly in front of the building and would include people who wanted to participate in "non-violent direct action." Ostensibly, they would create a human barrier between the building and the cops. This could look like a 'human-chain' or sitting down with locked arms, etc.

The *third zone* was to be people in the street "assertively fighting" the cops and bringing their attention away from the building and the people inside. Some thoughts about this included breakaway marches or just antagonizing the police while they were attempting to evict the occupation.

relatively close to Oscar Grant Plaza;

is relatively easy to get into;

be in a neighborhood where its impact on neighbors would be relatively low.

The proposal passed and the Move-In Day Assembly was created. The Assembly had meetings twice a week. Decisions were mostly made in committees, but were coordinated by the larger group. The committees were as follows:

Entry/Tactical. A closed group charged with deciding which building to occupy and how to get into it. It also needed to coordinate between the different committees on the day of the occupation.

Building Committee. People interested in decorating, defending, and maintaining the building once it was taken. Also had a security team, which would work to resolve conflicts between individuals and coordinate defense against eviction.

Logistics Committee. This group planned the rally and march to the building. They coordinated how supplies, like furniture and food, would get to the building.

Festival Committee. They created a huge move-in day festival where there were many speakers, performers and

panels planned. This formed the primary reason for a large number of people to be inside the building.

Media. Worked on publicity for the event, creating the website, facilitating media coverage, coming up with public statements, coordinating outreach, etc.

Move-in Day

Due to the relative transparency of the occupation, people felt an intense investment in their future social center. There was an entire month of planning – the imaginary element of what could potentially happen created the resolve that led to people fighting so fiercely on January 28th (J28), the day of the occupation.

The march started at Oscar Grant Plaza in Downtown Oakland. Initially, the police tried to confiscate the sound truck, which delayed the march and made communication between the tactical team and the rest of the march difficult. When the march neared the Kaiser building, police lines were already in formation, ready to repel our advances.

The crowd, which hadn't yet developed its will and confidence to advance against a police line, decided to go through the adjacent community college campus. This disoriented the march. Re-grouping was difficult. By the time the march emerged from the

campus (having had to squeeze across a narrow bridge), police completely surrounded the Kaiser Center. Attempts to tear down the fence in front of the police were met with smoke bombs and tear gas.

Frustrated they were not able to reach their target, people continued onto Oak Street, where they advanced upon the police lines. The resolve and ferocity with which people fought was surprising. However, this response was probably due to a month of planning



At the Oak street standoff, this man's shield was a floral red armchair.

and preparing wherein people became attached to the idea of a permanent social center. Supplies gathered before the occupation were used during the march for defense. After thirty minutes of "fending off" police projectiles and tear gas, the march continued to

Oscar Grant Plaza where people regrouped for a couple of hours.

At 5pm, people unsuccessfully attempted to seize the Traveler's Aid building. The march continued from there and got kettled several blocks away at 19th and Telegraph, but evaded arrest by charging through a chain-link fence. Regrettably, after a snake march away and then back toward downtown, the cops successfully kettled a large group of people near the local YMCA. Those who avoided arrest temporarily occupied City Hall and also marched to the jail in solidarity with those being arrested.

ONWARD

It is a standard trick of politicians – radical or otherwise – to describe an occupation as a tactic within a specific program or as part of a particular ideology. We would like to argue that an occupation is fundamentally the opposite of this – it is a space where all normal social and political identities are transformed. In other words, an occupation forges alliances and social relationships due to its inherent antagonism to the status quo. If the occupation has a goal at all, then it must be the expansion of occupations – across the neighborhoods, across the city, across the nation . . .

Occupations always require a strategy, which is local, particular and situational as opposed to the abstraction of politics or ideology. To distance

ourselves from those who wish for occupations to be part of some political program, we will not articulate or suggest any specific ways forward. Instead, we will end with a series of questions that address what we find to be common tensions in the discussion of occupations to encourage the development of a localized strategy.

* * *

The occupation generates a world that is in stark contrast to our day-to-day lives of work, debt, and isolation. Yet, when an occupation comes to an end, these two worlds become separated from one another once again, as we return to the miseries of everyday life. Rather than swinging between moments of struggle and our daily grind,

how do we create a life and a struggle for ourselves that can be in constant play with each other?

Occupations are, by their nature, temporary. They are able to carve out a space for living and struggling for a distinct period of time. These spaces are antagonistic and a threat to the state and capitalism, as well they should be. Yet, we must pose the question: Is an indefinite occupation desirable? If so, how will it be achieved?

Occupations often act on a projected longevity (a vision of a future social center or providing people a place to sleep throughout the colder months) in order to galvanize support and clarify a positive vision. How much material investment do these visions deserve? How is this weighed against material investment in defending or fighting for the possibility of a very short-lived occupation?

The preservation of an occupation often grows tiresome to its participants. A time seems to come when the preservation of an occupation overtakes its subversive activity. How can subversive

activity be maintained? When should an occupation come to a conscious end so activity can continue elsewhere?

Clandestine and public organization are sometimes seen as incompatible with each other. To think it is either one or the other is a false opposition. They are a few out of many methods to be potentially used when seizing a space. How is it best to resolve this false tension between clandestine and public organization, taking the beneficial aspects from each?

If we wish to see occupations spread and become generalized, we must also generalize a particular technical know-how. Yet these skills are oftentimes not generalized forms of knowledge, an inevitable consequence of our society's division of labor. In a high stake situation, how do we combat the specialization of important tasks?

The occupation is the interruption of the flow of power and capital within a specific space and time. How can an occupation be amplified by, or amplify, other forms of interruption such as strikes, blockades, or expropriation?

The occupation must spread to survive. What would happen if we could take over the whole city, living without the imposition of the state or capitalism?

MATERIALS LISTS & DIAGRAMS

Entering the Building

Hand over hand method. Two crowbars, preferably around a meter long. A large hammer. Sometimes, a wonder bar (a slim, small pry bar) can help open the door for the insertion of the first larger pry bar.

Cylinder Removal. A hammer and large flathead screwdriver to create space to hook the crowbar behind the cylinder. A large crowbar. A small screwdriver to work the mechanism in the absence of a cylinder. See the diagram at the end of the last section.

Defending the March

Corrugated metal banner. 2 pieces of corrugated metal (commonly 72" by

25.75 inches). Three lengths of 1x4 wood, 72" long. 4 Lengths of 1x4 wood, 46" long. 6 large utility handles.

Trash can shield. 1 large trash can, cut in half. Cardboard. 1 trash can lid. Rope or discarded bike tubes. Utility knife to cut hole in cardboard and trash can.

Barricading Doors

Classic Method. 2 or more c-clamps per pushbar doors. Cable locks.

Bold new Method. Truck tie-downs with 10+ feet of webbing. Heavy furniture.

Entry

Angle Grinder

Use an angle grinder to cut through locks, bolts and chains. Cordless models are obviously preferable. Reliable and capable, but also noisy and time-consuming.

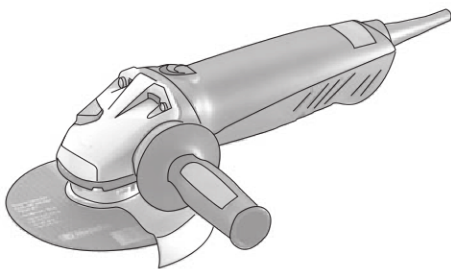

Bolt Cutters

Use bolt cutters to clip padlocks, lock boxes, or fencing. The 18" length will perform most tasks well and fit discreetly in a backpack or messenger bag.

Crowbar

Use this side of a crowbar to pry open windows and doors (such as in the hand over hand method). Use the area marked with an asterisk (*) as your fulcrum - pushing it against the window frame or door jamb.

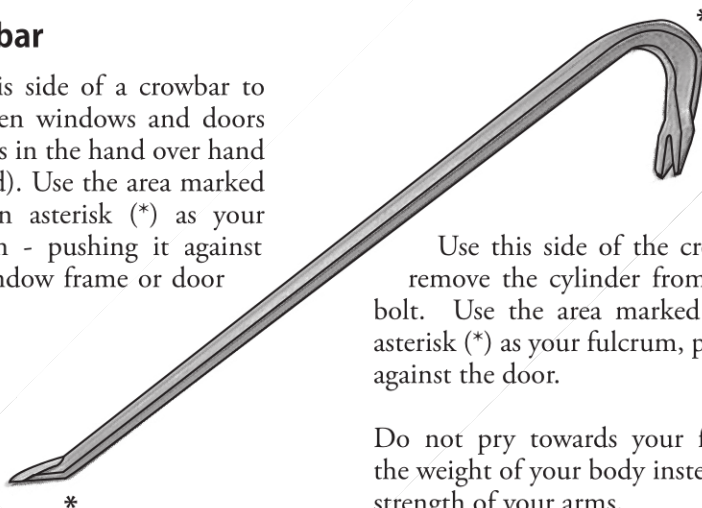

Use this side of the crowbar to remove the cylinder from a dead-bolt. Use the area marked with an asterisk (*) as your fulcrum, pushing it against the door.

Do not pry towards your face. Use the weight of your body instead of the strength of your arms.

If these less-destructive methods don't work, more aggressive options are abundant. Use a crowbar to open a window. Cheap Milgard latches and latches on older aluminum windows often break in place, keeping entry discreet. Older latches screwed into wood frames, double latched windows, or outswing casement windows that open by turning a handle are harder to break—often, the glass will be broken in the attempt.

On wooden doors with unreinforced cylinders, the entire cylinder can be removed with the curved end of a crowbar and the mechanism worked with a flathead screwdriver.

A pair of crowbars can be used to open doors. Start a crowbar as far away from the lock as possible (the bottom or top of the door). Open the door as much as possible, then insert the next crow-

bar closer to the lock. Work towards the lock, each crowbar opening the door to allow for the insertion of the next one. Once the sequence reaches the lock, there should be enough force to pop a deadbolt out of the frame. This technique is used by firemen and criminals the world over.

Don't be fooled by the appearance of security. Often, an expensive lock will be locked to a cheap chain, a high-security lockbox will be attached to a flimsy fence, a window can be removed because it was improperly installed, the vent on the roof of the warehouse can be detached to leave a person-sized opening, a window will be left unlocked on the second floor, a crawlspace will be accessible from the outside, or a pet door will allow you to reach the door locks from the outside. Brute entry is never preferable to more elegant solutions.

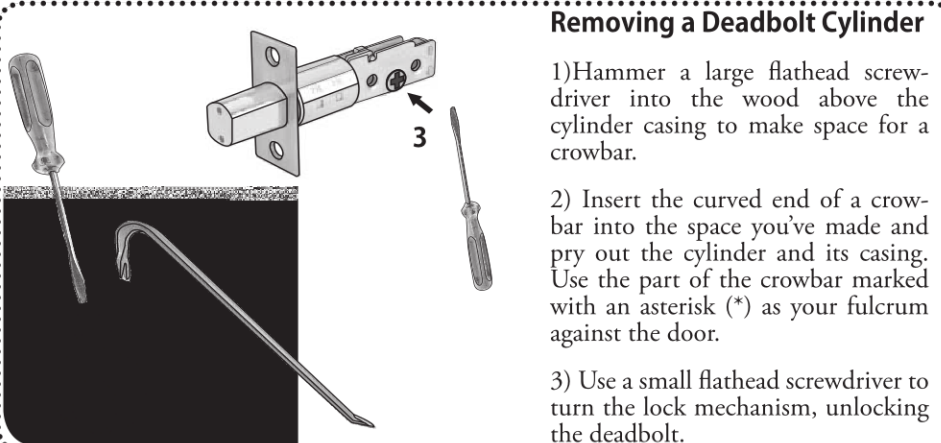

Removing a Deadbolt Cylinder

- 1) Hammer a large flathead screwdriver into the wood above the cylinder casing to make space for a crowbar.
- 2) Insert the curved end of a crowbar into the space you've made and pry out the cylinder and its casing. Use the part of the crowbar marked with an asterisk (*) as your fulcrum against the door.
- 3) Use a small flathead screwdriver to turn the lock mechanism, unlocking the deadbolt.

March Defense

Corrugated Metal Banner

Overlap two pieces of 72" by 25.75" corrugated steel, for a total size of around 46" by 72". Screw vertical wooden supports directly to the metal, preventing flex. Attach horizontal supports to the vertical supports. The six utility handles are attached as shown. The goal of this arrangement was to allow a maximum number of people to hold the shield while remaining protected by it. You can use inexpensive fasteners (drywall screws or the like). Pre-drill the holes in the metal. Paint an appropriate slogan on the face of the banner.

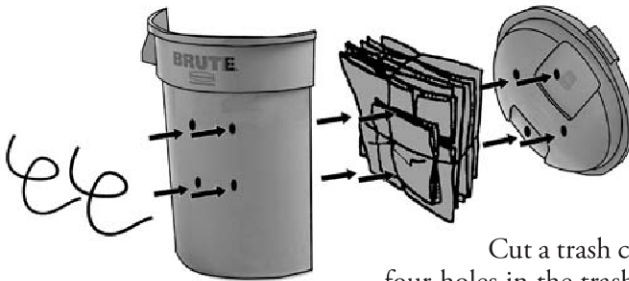
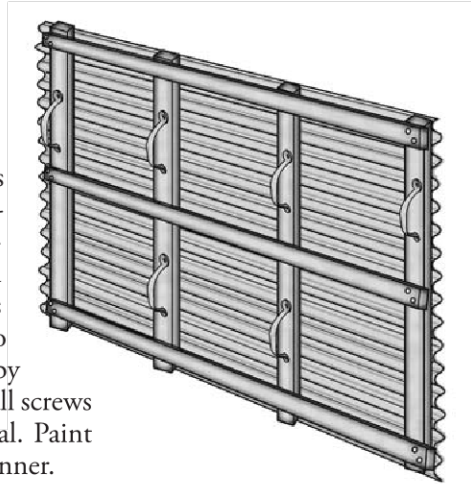

Trash Can Shield

Cut a trash can (40-45 gallon) in half. Cut four holes in the trash can as shown above. Thread two lengths of rope, hose, or bike tube side by side through those holes. Stack cardboard on the inside of the trashcan, cutting holes in it to feed the straps through. Finally, cut a corresponding set of holes in a trash can lid and put it against the cardboard. Tie off the straps so they form two vertical handles, which the shield's user will slip her forearm through.

Barricading Doors

The “classic” method

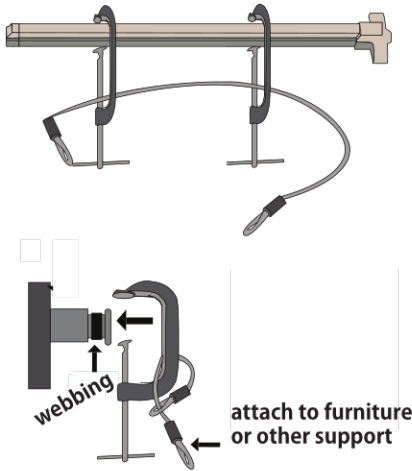

Pushbar doors. By the “classic” method, prevent the pushbar from pushing by clamping webbing to it. Attach the clamps to a structural support with a length of metal cable.

If a space exists between the pushbar and the door, the “bold new” method might be more appropriate. Loop one or more pieces of webbing through the space between the pushbar and the door. Loop the same piece of webbing around a piece of furniture larger than the doorway. Ratchet the webbing tight, tighter than you’ve ever done it. For added strength, use multiple pieces of webbing (student occupations) or use chain (75 River).

Doors with turning handles. Loop one end of a cable lock around the door handle. Tie the other end to a structural support or loop it around another door handle.

Doors with no handles. These are almost impossible to secure without damaging the doors. Unless they open into the occupied space, avoid them. If they can’t be avoided, screw or nail them shut.

Windows. Unless they are plexiglass, the easiest way for the police to open a window is to break it. Cover it with plywood, a metal grate, or both.

The “bold new” method

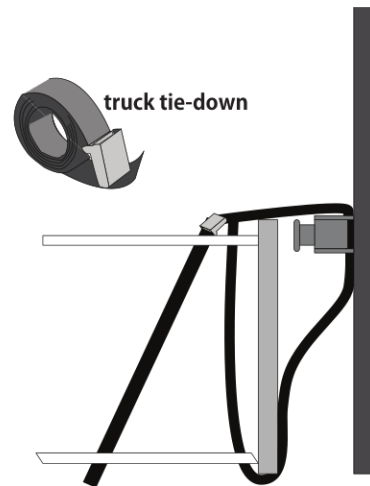

SUGGESTED READING

Occupation: A Do-It-Yourself Guide. The Imaginary Committee.

Pre-Occupied: The Logic of Occupation. The Inoperative Committee.

The New School Occupation: Perspectives on the Takeover of a Building.
Various Authors.

On Martial Traditions and the Art of Rebellion. Seaweed.

20 Theses on the Subversion of the Metropolis. Anonymous.

The Subversion of Politics. George Kastiaficas.

Squatter's Handbook: "Political" Squatting Tips. Homes not Jails.

Expedient B&E: Tactics and Techniques for Bypassing Alarms and Defeating Locks. Paladin Press.

The Complete Guide to Lockpicking. Loompanics Unlimited.

The most important appointment
is always on the barricades Alfredo Bonnano

THE DO-IT-YOURSELF OCCUPATION GUIDE