



ALL WEATHER
FIELD
OPERATING GUIDE
Nº 573

Name _____

Phone Number _____

Team _____

Team leader _____

Leader Phone _____

CERT Coordinator _____

Coordinator Phone _____

EOC _____

Staging Area _____

Rite in the Rain – A patented, environmentally responsible, all-weather writing paper that sheds water and enables you to write anywhere, in any weather. Using a pencil or all-weather pen, *Rite in the Rain* ensures that your notes survive the rigors of the field, regardless of the conditions.

Table of Contents

CERT Quick Reference Field Operating Guide

Equipment Checklist	R-1
Water Purification	R-2
Triage Flowchart	R-3
Triage Procedures	R-4
Utility Shutoffs	R-5
Fire Fighting	R-6
Hazardous Materials	R-7
HAZMAT DOT Placards	R-8
Physical Search	R-9
Leveraging and Cribbing	R-10
Arrangement for Cribbing / Leveraging	R-11

Disaster Preparedness

CERT Actions / Size-up in a Disaster	1
Preparing for a Disaster	2
Protective Actions	3
Structural and Non-structural Mitigation	4

Disaster Medical Operations

Public Health Considerations	5
Bloodborne Pathogen Safety Procedures	6
Triage in a Disaster Environment	7
Patient Flowchart	8
Conducting Head-to-Toe Assessments	9-10
Components of the Respiratory System	11
Opening the Airway	12
Head-Tilt / Chin-Lift Method	13
Controlling Bleeding	14
Procedures for Controlling Bleeding	15
Methods for Controlling Bleeding	16
Burn Treatment	17-18
Hypothermia Treatment	19

Fire

Deciding to Use a Fire Extinguisher	20
Elements Required for Fire	21
Hazardous Materials	22
Hazards in Transit	23

Search and Rescue Operations

Deciding to Attempt a Rescue	24
Search and Rescue Size-up Checklist	25
Rescue Lifts and Carries	26-31

Flood

Expedient Flood Training	32-35
--------------------------	-------

Hazards

Floods	36
Earthquakes	37
Fires & Wildfires	38
Excessive Heat	39
Hurricanes	40
Landslides and Mud Flows	41
Severe Thunderstorms	42
Tornadoes	43
Tsunamis	44
Volcanoes	45
Winter Storms	46
Nuclear Power Plant	47
Pandemic Influenza	48

CERT Organization

CERT Team Organization	49
CERT Organization	50
CERT Operations	51
Operations Section Chief	52
CERT Mobilization	53
Rescuer Safety	54
Determining a Damage Site	55
Documentation	56

Psychology

Team Well-Being	57
Working with Survivors' Trauma	58

CERT and Terrorism

Terrorism	59
-----------	----

Personal Information

Contact Numbers	60
CERT Record of Course Training	61
CERT Volunteer Record	62
CERT Exercise Training Record	63
NOAA & EAS Radio Frequencies	64

CERT Equipment Checklist

Water (2 canteens or bottles per team member)

Dehydrated foods or MREs

Water purification tablets

Leather work gloves

Non-latex exam gloves
(min. of 10 pair)

Goggles

N95 masks

Flashlight or head lamp

Batteries/extra bulbs

Secondary flashlight

Cyalume sticks (min. of 4)
(12 hr. omni glow)

Voltage tick meter

Note pads

Pens/Pencils

Markers:

- Thin point
- Thick point

Non-sparking crescent wrench

Duct tape

Masking tape (2")

Scissors (EMT shears)

Triage tape - All colors of tape

Tag Utility knife

First Aid Pouch containing:

- 4"x4" gauze dressings (6)
- Abdominal pads (4)
- Triangular Bandages (4)
- Band Aids
- Roller Bandage (2" & 4" bandage or battle dressings)
- Any personal medications that CERT members might need during deployment

Pea-less Whistle

Rite in the Rain Forms Book

Rite in the Rain F.O.G.

Rite in the Rain Pen

Rite in the Rain Safety

Assessment Placards:

- GREEN "Inspected"
- YELLOW "Restricted Area"
- RED "Danger"

Before you leave home...

- Check family and pets to ensure safety
- Inspect house and property for damage
- Inspect utilities and secure as needed
- Call out-of-state contact at _____
- Get family disaster supplies
- Assist immediate neighbors

Water Purification

If you have questions about the quality of the water, purify it before drinking. You can heat water to a rolling boil for 1 minute or use commercial purification tablets or an EPA approved water filtration unit to purify the water. You can also use household liquid chlorine bleach if it is pure, unscented and 5.25% sodium hypochlorite.

To purify water with chlorine bleach, use the table below as a guide:

Clear Water

Water Quantity	Bleach Added
1 Quart	2 Drops
1 Gallon	8 Drops
5 Gallons	1/2 Teaspoon

Note: If water is cloudy, double the recommended dosage of bleach.

After adding bleach, shake or stir the water container and let stand 30 minutes before drinking. Toxic chemicals can also contaminate floodwater. Do NOT try to treat or drink floodwater.

Triage Flowchart

Step 1
Check Airway/ breathing

Is the person breathing?

No

Reposition Airway.
Now breathing?

No

After 2 attempts tag
"Dead"

Yes

Check breathing rate

Less than 30 per
minute

More than 30 per minute

Check circulation and control bleeding

"I"
Treat for shock

Step 2
Check Circulation and Control Bleeding

Control Severe Bleeding

Check radial pulse

Perform the
Blanch Test

Present

Absent

More than
2 seconds

Less than
2 seconds

Check mental
status

"I" Treat for
bleeding and shock

"I" Treat for shock

Check mental
status

Step 3
Check mental status

Fails to follow simple commands

Follows simple commands

"I" Treat for shock

"D" Delayed

For more information see pages 5-19 in Medical

Triage Procedures

- **Step 1: Stop, Look, Listen and Think.** Before your team starts, stop and size up the situation by looking around and listening. THINK about your safety, capability, and limitations, if you decide to proceed, make a plan about your approach that all members understand.
- **Step 2: Conduct voice triage.** Begin by calling out, “Community Emergency Response Team. If you can walk, come to the sound of my voice.” Speak loudly and firmly. If there are survivors who are ambulatory, tag them “M” and direct them to a designated location. If rescuers need assistance and there are ambulatory survivors, then these survivors should be asked to provide assistance. These persons may also provide useful information about the location of the other victims.
- **Step 3: Start where you stand and follow a systematic route.** Start with the closest victims and work outward in a systematic fashion.
- **Step 4: Evaluate each victim and tag them.** “I” (immediate), “D” (delayed), “M” (minor), or “DEAD”. Remember to evaluate the walking wounded. Remember to ASK for permission to treat.
- **Step 5: Treat “I” victims immediately.** Initiate airway management, bleeding control and or treatment for shock for “I” victims.
- **Step 6: Document triage results for:**
 - Effective deployment of resources.
 - Information on the victims’ locations.
 - A quick record of the number of casualties by degree of severity.

The rescuer’s safety is paramount during triage. Wear proper protective equipment so as not to endanger your own health.

Status	Tag Initial
Critical, immediate treatment	“I”
Injured, but delayed treatment	“D”
Minor or no injuries	“M”
Dead	“Dead”

For more information see pages 5-19 in Medical

Utility Shut-offs

Electrical Shut-offs

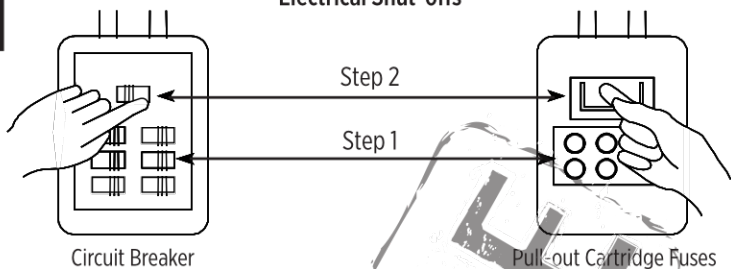

Water Shut-off

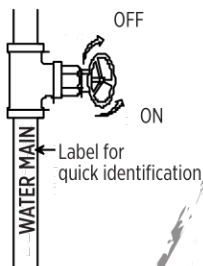

Gas Meter and Shut-off Valve

Have wrench stored in a specific location where it will be immediately available or use a team member's wrench or utility tool.

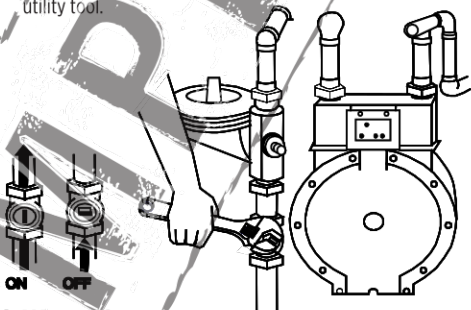





Utility Shut-offs: Electrical, Water, Gas

Turn off utilities **ONLY** if there are leaks, broken pipes or a strong smell (natural gas or propane).

- The electrical shut-off procedure shows both a circuit box and a fuse box and shows two steps. Step 1 is to turn off all individual breakers (or pull out individual fuses). Step 2 is to shut off the main circuit (or pull out main fuse).
- The water shut-off indicates a clockwise turn of the valve to shut off and a counterclockwise turn in order to turn on.
- The gas meter shut-off diagram indicates the shut-off valve location on the pipe that comes out of the ground. To turn off the valve, use a non-sparking wrench to turn the valve clockwise one-quarter turn **NEVER TURN THE GAS BACK ON**; let a professional do it!

Fire Fighting

Fire Types, Extinguishing Agents, and Methods

Fire Type	Extinguishing Agent	Extinguishing Method
Ordinary Solid Materials  A	Water	Removes heat
	Foam	Removes air and heat
	Dry chemical	Breaks chain reaction
Flammable Liquids  B	Foam CO ₂	Removes air
	Dry chemical	Breaks chain reaction
Electrical Equipment  C	CO ₂	Removes air
	Dry chemical	Breaks chain reaction
Combustible Metals  D	Special agents	Usually removes air
Kitchen Oils  K	Chemical	Usually removes air

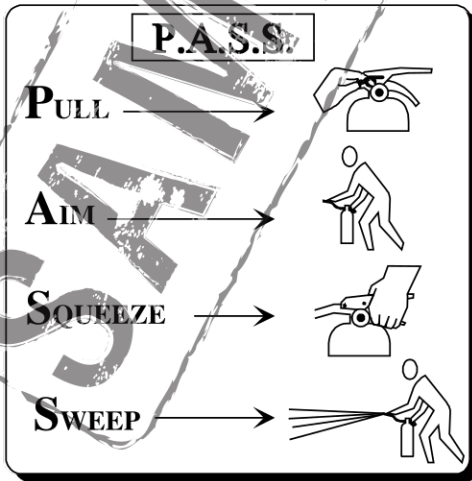

P.A.S.S.: Pull, Aim, Squeeze, Sweep — *Aim at the base of the fire!*

IF YOU FEEL YOU CANNOT PUT THE FIRE OUT ON YOUR OWN, EXIT THE LOCATION AND NOTIFY YOUR TEAM LEADER AND THE EOC IMMEDIATELY!

Hazardous Materials

Identifying Stored Hazardous Materials

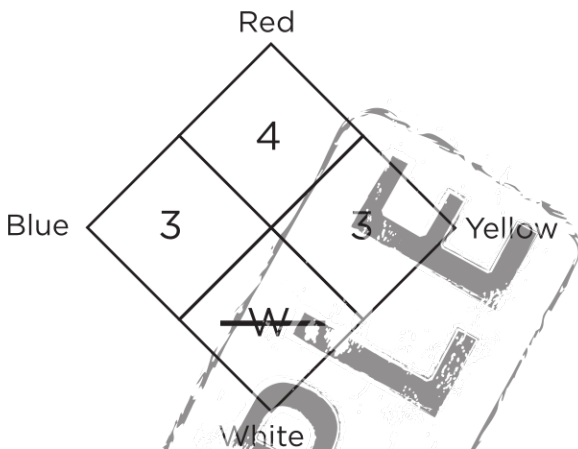

National Fire Protection Association 704 Diamond

The NFPA 704 Diamond, is divided into four colored quadrants, each with a rating number inside of it, which indicates the degree of risk associated with the material. Numbers range from 1 to 4.

“The higher the number the higher the risk!”

- The red quadrant describes the material's flammability, 0-4.
- The blue quadrant indicates health hazard, 0-4.
- The yellow quadrant indicates reactivity, 0-4.
- The white quadrant indicates special precautions.

The numbers within the 704 Diamond are for professional firefighter use only.

CERT members should consider these placards a “stop sign.”

The only action CERT members should take when a facility is placarded with an NFPA 704 Diamond is to call 911 and evacuate persons who are downwind, as necessary, to an uphill and upwind location. Do not enter the building in an attempt to evacuate persons inside.

Hazardous Materials

Identifying Hazardous Materials in Transit

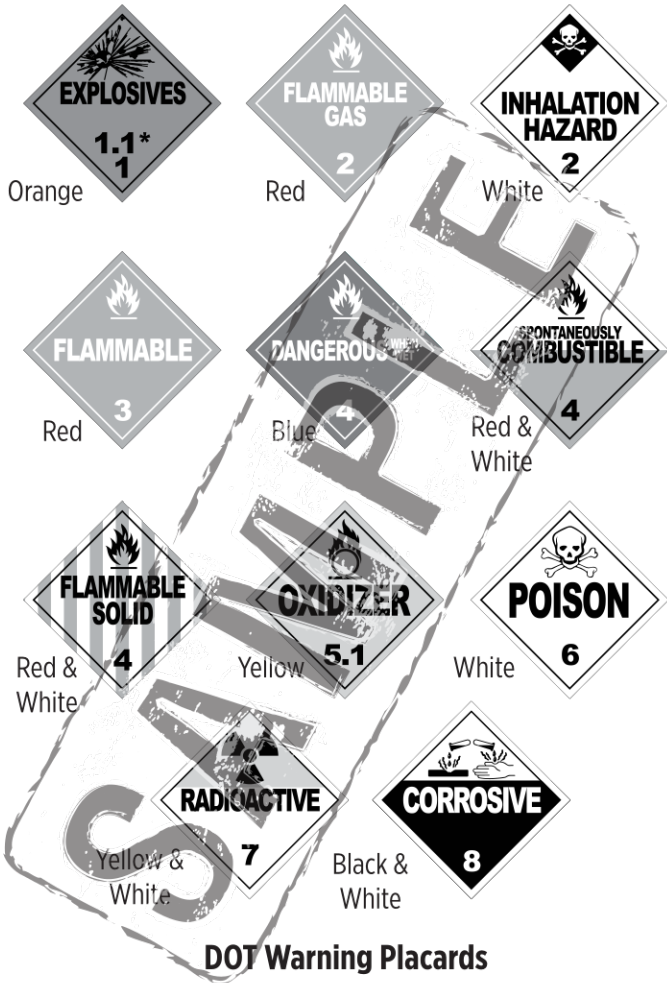

DOT Warning Placards

Like the NFPA 704 Diamond, the DOT, UN and NA placards should be a “STOP SIGN” for CERT members!

For more information see Fire page 23

Physical Search

Conducting Search Operations

Search Markings

1. Upon entering a search area, make a single slash “/” next to the door and write the agency or group ID at the “9 o’clock” position. Then write the date and “time in” at the “12 o’clock” position.
 2. Upon exiting the search area, make another slash to form an “X” (the agency or group ID will be in the left quadrant). Enter the search “time out” in the top quadrant.
- **Right quadrant:** Enter the areas of the structure searched and any specific information about hazards.
 - **Lower quadrant:** Enter information about victims found. “L” represents living, while “D” represents dead. The search marking on the front of a structure or building should contain the total number of victims. Also indicate where victims have been taken.

Information to Mark



Example Search Marking

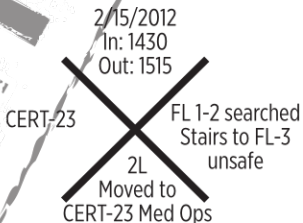

Systematic Room Search Pattern

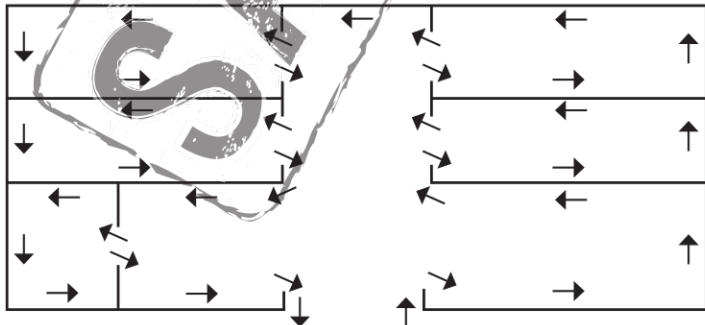

Use a bottom-up/top-down or right wall/left wall method to ensure that the entire building is searched.

Leveraging and Cribbing

You may encounter situations in which debris needs to be moved to free victims. In these situations, CERT rescuers should consider leveraging and cribbing to move and stabilize the debris until the rescue is complete.

- Leveraging is accomplished by wedging a lever under the object that needs to be moved, with a stationary object underneath it to act as a fulcrum. When the lever is forced down over the fulcrum, the far end of the lever will lift the object.
- A crib is a wooden framework used for support or strengthening.
- Box cribbing means arranging pairs of wood pieces alternately to form a stable rectangle.

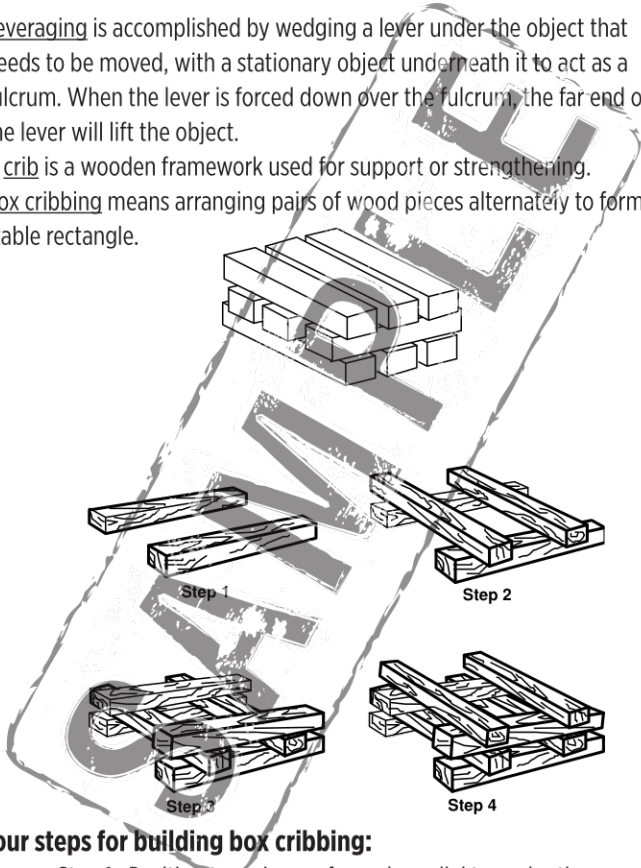

Four steps for building box cribbing:

- Step 1: Position two pieces of wood parallel to each other on either side of the collapse.
- Step 2: Place two pieces of wood perpendicularly across the base pieces.
- Steps 3 & 4: Add additional layers of wood. Each perpendicular to the previous level.

Arrangement for Cribbing/Leveraging Operation

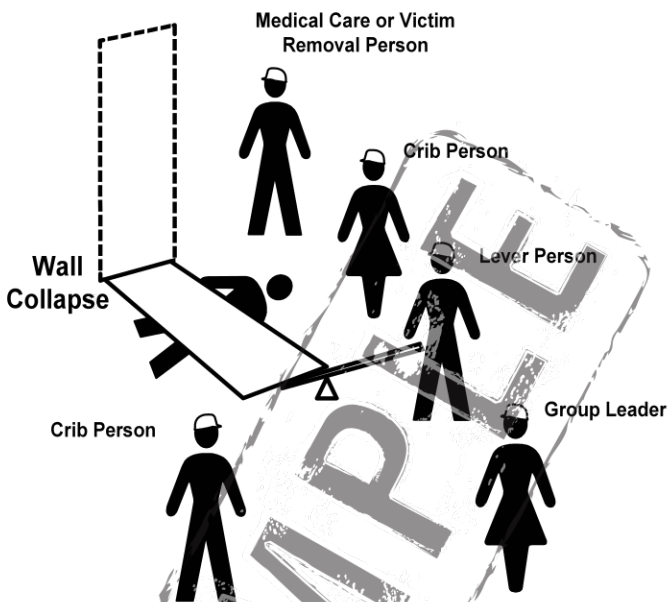

Team Organization for Leveraging/Cribbing Operation, showing the victim underneath a collapsed wall and the CERT members at the following locations:

- Group Leader: In front of collapse, positioned so that he or she can view the entire operation while remaining out of the rescuers' way and being able to provide command to group.
- Lever Person: At the front edge of the collapsed wall and positioned so that he or she can position a fulcrum and lever under the wall.
- Crib Persons: On either side of the collapsed wall and positioned to enable the placement of cribbing as the wall is raised with the lever.
- Medical Care/Victim Removal Person: Next to the Crib Person who is closest to the victim's head.

CERT Actions and Size-up in a Disaster

- Ensure that you and your family are safe.
- Locate your CERT equipment and keep it with you.
- Assist immediate neighbors. Conduct a neighborhood survey.
- Contact your CERT leader. If you cannot reach your CERT leader report to your pre-designated CERT staging area.
- **DO NOT START OUT ON YOUR OWN.**
- Document all messages and activities. Keep track of personnel at all times.
- Do the greatest good for the greatest number!

Steps to take for sizing up a disaster

- **Gather facts.** What has happened? How many people are involved? What is the current situation?
- **Assess and communicate the damage.** Try to determine what has happened, what is happening now, and how bad things can really get.
- **Consider probabilities.** What is likely to happen? What could happen through cascading events?
- **Assess your own situation.** Are you in immediate danger? Have you been trained to handle the situation? Do you have the equipment that you need?
- **Establish priorities.** Are lives at risk? Can you help?
REMEMBER THAT LIFE SAFETY IS THE FIRST PRIORITY!
- **Make decisions.** Base your decisions on the answers to Steps 1 through 5 and in accordance with the priorities that you established.
- **Develop plans of action.** Develop a plan that will help you accomplish your priorities. Simple plans may be verbal, but more complex plans should always be written.
- **Take action.** Execute your plan, documenting deviations and status changes so that you can report the situation accurately to first responders.
- **Evaluate progress.** At intervals, evaluate your progress in accomplishing the objectives in the plan of action to determine what is working and what changes you may have to make to stabilize the situation.

Preparing for a Disaster

Many preparedness actions are useful in any type of emergency situation, and some are specific to a particular type of disaster. A critical first step to preparedness is to understand the hazards in your community and to learn about local alerts and warning systems, evacuation routes and sheltering plans. It is also important to familiarize yourself with hazards in other areas when you are traveling and may experience a type of hazard you are not as familiar with.

Regardless of the type of disaster, important elements of disaster preparedness include:

- Having the skills to evaluate the situation quickly and to take effective action to protect yourself.
- Having a family disaster plan and practicing the plan with drills.
- Assembling supplies in multiple locations.
- Reducing the impact of hazards through mitigation practices.
- Getting involved by participating in training and volunteer programs.

It is also always important to address specific needs for yourself and people you know; including any access or functional needs, considerations for pets and service animals and transportation.

Protective Actions

Because many disasters occur with little or no warning, individuals need to have the knowledge and skills to take immediate protective actions in the first critical moments after a disaster has occurred. While the specific action to take is based on the disaster type, the amount of warning, whether you are inside, outside or driving, and the amount of training you have, the following list provides a good overview of the protective actions you should be familiar with.

Assess the situation. Identify the type of event and whether air or a building structure has been compromised.

Decide to stay or change locations. In some instances you should stay where you are (if an event has occurred outside, you may need to stay inside) and in other situations you should change location (if the event is inside, you may need to evacuate the building).

Staying or changing location is a critical early decision in disasters.

If you are not in immediate danger, you should stay where you are and get more information before taking your next steps. While you may need to make the first, immediate decision, it is important that you listen to local authorities when information is provided. If experts tell you to evacuate from your location, LEAVE!

Seek clean air and protect breathing passages. Regardless of the type of disaster, clean air is a critical need. Actions to protect your airways and seek clean air may include covering your mouth with a cloth or mask, vacating the building, or sheltering in place by sealing an internal room while the airborne contaminant dissipates.

Protect yourself from debris and signal rescuers if trapped. If you become trapped, protect your airways, bang on an object, or blow a whistle. Yelling should be a last resort.

Remove contaminants. If contaminants have been released into the area or you have made contact with liquid or solid contaminants, it is critical that you remove the contaminants as quickly as possible. Remove contaminated clothing and wash with soap and water starting at the head and working toward the feet.

Practice good hygiene. Clean drinking water and sanitation are important protective actions.

Structural and Non-structural Mitigation

Precautions Against Structural and Non-structural Hazards

Type of Hazard	Sample Precautions
Structural	<ul style="list-style-type: none">• Bolt older houses to the foundation.• Install trusses or hurricane straps to reinforce the roof.• Strap propane tanks and chimneys.• Strap mobile homes to their concrete pads.• Raise utilities (above the level of flood risk).• Ask a professional to check the foundation, roof connectors, chimney, etc.
Non-structural	<ul style="list-style-type: none">• Anchor such furniture as bookshelves, hutches, and grandfather clocks to the wall.• Secure appliances and office equipment in place with industrial-strength Velcro®.• Install hurricane storm shutters to protect windows.• Secure cabinet doors with childproof fasteners.• Locate and label shutoffs for gas, electricity, and water before disasters occur. After a disaster, shut off the utilities to prevent fires and other risks. Store a non-sparking shutoff wrench where it will be immediately available. If you shut off gas, DO NOT turn the gas back on before the area has been inspected by the utility company!• Teach all home occupants, including children who are old enough to handle the responsibility, when and how to shut off the important utilities.• Secure water heaters to the wall to safeguard against a ruptured gas line or loose electrical wires.

Public Health Considerations

When disaster victims are sheltered together for treatment, public health becomes a concern. Measures must be taken, both by individual CERT members and CERT operations, to avoid the spread of disease.

The primary public health measures include:

- Maintaining proper hygiene
- Maintaining proper sanitation
- Purifying water (if necessary)
- Preventing the spread of disease

Maintaining Hygiene

Maintenance of proper personal hygiene is critical even under makeshift conditions. Some steps to take to maintain hygiene are to:

- **Wash hands frequently** using soap and water and hand sanitizer. Hand washing should be thorough (at least 15-20 seconds of vigorous rubbing on all surfaces of the hand). Alcohol-based hand sanitizers -which don't require water- are a good alternative to hand washing. The Centers for Disease Control (CDC) recommends products that are at least 60% alcohol. To use an alcohol-based hand sanitizer, apply about 1/2 teaspoon of the product to the palm of your hand. Rub your hands together, covering all surfaces, until hands are dry.
- **Wear non-latex exam gloves at all times.** Change or disinfect gloves after examining and/or treating each patient. Under field conditions, individuals can use rubber gloves that are sterilized between treating victims using bleach and water (1 part bleach to 10 parts water).
- **Wear an N95 mask and goggles.**
- **Keep dressings sterile.** Do not remove the over wrap from dressings until use. After opening, use the entire package of dressing, if possible.
- **Thoroughly wash areas that come in contact with body fluids** with soap and water or diluted bleach as soon as possible.

Bloodborne Pathogen Safety Procedures

Fundamental to the bloodborne pathogens standard is the concept of Universal Precautions. This concept is the primary mechanism for infection control. It requires treating all blood, bodily fluids, or other potentially infectious materials as if infected with bloodborne disease. Take protective measures to avoid contact with potentially infectious materials.

- CERT members should recognize that Human Immunodeficiency Virus (HIV), Hepatitis B Virus (HBV), Hepatitis C Virus (HCV), and other pathogens may be present in blood, bodily fluids and in unfixed tissues or organs.
- Bodily fluids of concern are blood, semen, vaginal secretions, cerebrospinal fluid, synovial fluid, pleural fluid, saliva from dental procedures, any bodily fluid with visible blood and any unidentifiable bodily fluid. Feces and vomit should also be considered potentially infectious, since they may contain blood.
- Bodily fluids which are generally NOT considered potentially infectious include nasal secretions, sputum, sweat, tears and urine.
- Pathogens can enter the body through cuts, nicks, skin abrasions and the mucous membranes of the mouth, eyes, or nose.
- All blood or other bodily fluids of concern, as described above, should be assumed to be infectious. Universal Precautions should be followed when working with these potentially infectious materials.
- Prohibit eating, drinking, smoking or applying cosmetics where human blood, bodily fluids, or other potentially infectious materials are present regardless of personal protection that may be worn. Always use personal protection equipment (gloves, masks, etc...) when coming in contact with blood or other bodily fluids.

Triage Procedures

Step 1: Stop, Look, Listen and Think.

Step 2: Conduct voice triage.

Step 3: Start where you stand, and follow a systematic route.

Step 4: Evaluate each victim and tag them.

Step 5: Treat "I" victims immediately.

Step 6: Document triage results for:

- Effective deployment of resources.
- Information on the victims' locations.
- A quick record of the number of casualties by degree of severity.

The rescuer's safety is paramount during triage. Wear proper protective equipment so as not to endanger your own health.

Triage in a Disaster Environment

Evaluating A Victim During Triage

Step	Procedures
1	<p>Check airway/breathing. At an arm's distance, make contact with the victim and speak loudly. If victim does not respond:</p> <ul style="list-style-type: none">• Position the airway.• Look, listen, and feel.• Check breathing rate. Abnormally rapid respiration (above 30 per minute) indicates shock. Maintain the airway and treat for shock and tag "I".• If below 30 per minute, then move to Step 2.• If the victim is not breathing after 2 attempts to open airway, tag "DEAD".
2	<p>Check circulation/bleeding:</p> <ul style="list-style-type: none">• Take immediate action to control severe bleeding.• Check circulation using the blanch test (for capillary refill) or radial pulse test.• Press on an area of skin until normal skin color is gone. Treat for shock if normal color takes longer than 2 seconds to return, and tag "I".• Or check the radial pulse. If present, continue to step 3.• Note if the pulse is abnormal (rapid, thready, weak, etc.).• If absent, tag "I" and treat for bleeding and shock.
3	<p>Check mental status. Inability to respond indicates that immediate treatment for shock is necessary. Treat for shock and tag "I".</p>

If the victim passes all tests, his or her status is "D". If the victim fails one test, his or her status is "I". Remember that everyone gets a tag. All victims tagged "I" get airway control, bleeding control and treatment for shock.

Disaster Medical Operations

Patient Flowchart

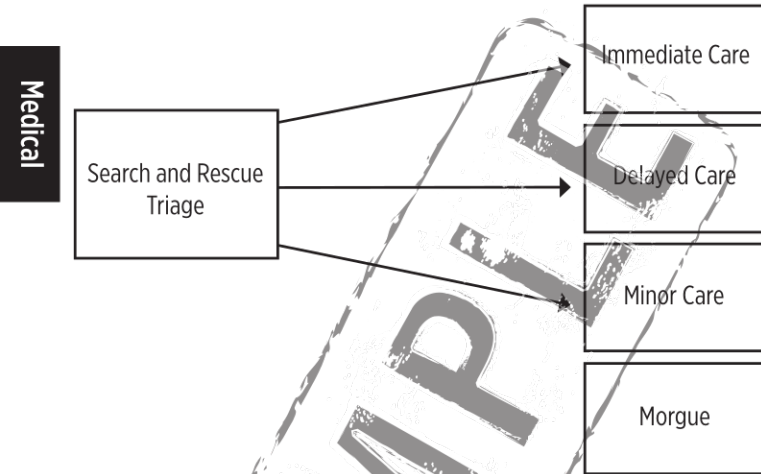

The first steps that you will take when working with a victim will be to conduct triage and rapid treatment. After all victims in an area have been triaged and moved to a medical treatment area, CERT members will begin a thorough head-to-toe assessment of each victim's condition.

During triage, you are keeping an eye out for the “killers”:

- Airway obstruction
- Excessive bleeding
- Signs of shock

A head-to-toe assessment goes beyond the “killers” to try to gain more information to determine the nature of the victim's injury. The entire assessment must be performed before initiating treatment.

Conducting Head-to-Toe Assessments

What to Look for in Head-to-Toe Assessments

The medical community uses the acronym DCAP-BTLS to remember what to look for when conducting a rapid assessment. DCAP-BTLS stands for the following:

- Deformities
- Contusions (Bruising)
- Abrasions
- Punctures
- Burns
- Tenderness
- Lacerations
- Swelling

When conducting a head-to-toe assessment, CERT members should look for DCAP-BTLS in all parts of the body.

Remember to provide IMMEDIATE treatment for life-threatening injuries.

You should pay careful attention to how people have been hurt (the mechanism of injury) because it provides insight to probable injuries suffered. For example, crushed under building, cut by flying glass, hit by flying objects or smoke inhalation.

Check body parts from the top to the bottom for continuity of bones and soft tissue injuries.

While conducting a head-to-toe assessment, CERT members should always check for:

- PMS (Pulse, Movement, Sensation) in all extremities
- Medical ID emblems such as “medic alert” on bracelet or on neck chain

Conducting Head-to-Toe Assessments

Signs of a Closed-Head, Neck or Spinal Injury

The signs of a closed-head, neck or spinal injury most often include:

- Change in consciousness
- Inability to move one or more body parts
- Severe pain or pressure in head, neck, or back
- Tingling or numbness in extremities
- Difficulty breathing or seeing
- Heavy bleeding, bruising or deformity of the head or spine
- Blood or fluid in the nose or ears
- Bruising behind the ear
- “Raccoon” eyes (bruising around the eyes)
- “Uneven” pupils
- Seizures
- Nausea or vomiting
- Victim found under collapsed building material or heavy debris

If the victim is exhibiting any of these signs, he or she should be treated as having a closed-head, neck or spinal injury.

Remember: Moving victims with suspected head, neck or spinal injury requires sufficient victim stabilization. If the rescuer or victim is in immediate danger, however, safety is more important than any potential spinal injury and the rescuer should move the victim from the area as quickly as possible.

Disaster Medical Operations

Components of the Respiratory System

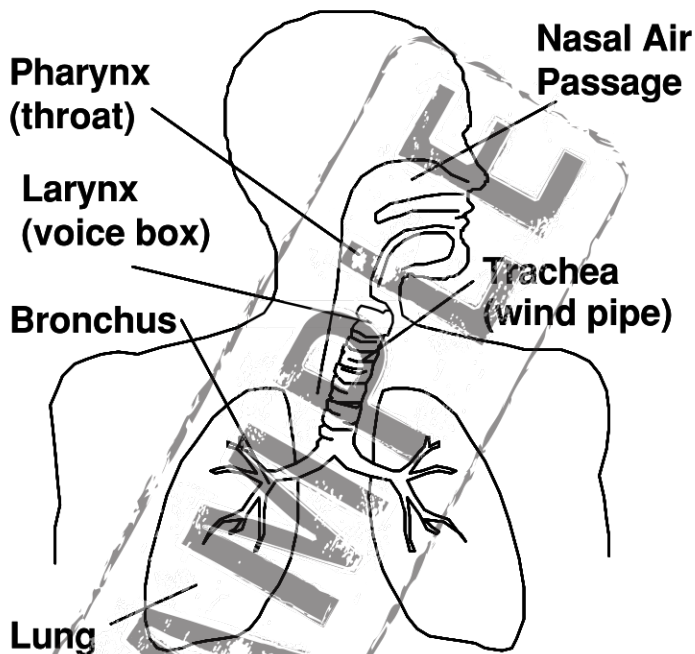

Components of the Respiratory System, showing the pharynx, nasal air passage, larynx, trachea and bronchus.

The respiratory system includes airways, lungs and muscles.

Disaster Medical Operations

Opening the Airway

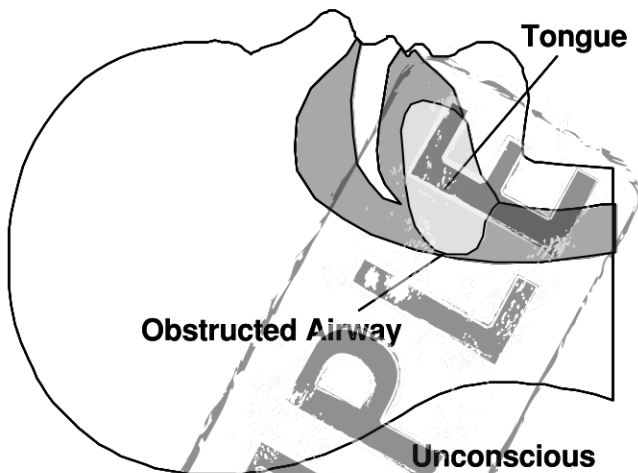

The most common airway obstruction is the tongue. In an unconscious or semiconscious victim, especially one positioned on his or her back, the tongue, which is a muscle, may relax and block the airway. A victim with a suspected airway obstruction must be checked immediately for breathing and, if necessary, the airway must be opened.

When an airway obstruction is suspected, CERT members should clear the airway using the Head-Tilt/Chin-Lift method. This method causes little or no cervical-spine manipulation because only the head is manipulated.

Proper technique is always important, but so is speed.

Disaster Medical Operations

Head-Tilt / Chin-Lift Method for Opening an Airway

Step	
1	At an arm's distance, make contact with the victim by touching the shoulder and asking "Can you hear me?" loudly but do not shout.
2	If the victim does not or cannot respond, place the palm of one hand on the forehead.
3	Place two fingers of the other hand under the chin and tilt the jaw upward while tilting the head back slightly.
4	Place your ear close to the victim's mouth, looking toward the victim's feet, and place a hand on the victim's abdomen.
5	Look for chest rise.
6	Listen for air exchange. Document abnormal lung sounds (wheezing, gasping, gurgling, etc.)
7	Feel for abdominal movement.
8	If breathing has been restored, the airway still must be maintained by keeping head tilted back. If breathing has not been restored, repeat steps 2-7.

Part of your mission is to do the greatest good for the greatest number of people. For that reason, if breathing is not restored on the first try using the Head-Tilt/Chin-Lift method, CERT members should try again using the same method. If breathing cannot be restored on the second try, CERT members must move on to the next victim.

If breathing has been restored, the airway still must be maintained. One option is to use a volunteer or walking wounded to hold the head in place. The airway can also be maintained by placing soft objects under the victim's shoulders to elevate the shoulders slightly to keep the airway open.

Disaster Medical Operations

Controlling Bleeding

Uncontrolled bleeding initially causes weakness. If bleeding is not controlled, the victim will go into shock within a short period of time, and finally will die. An adult has about five liters of blood. Losing one liter can result in death.

There are three types of bleeding and the type can usually be identified by how fast the blood flows:

- Arterial bleeding. Arteries transport blood under high pressure. Blood coming from an artery will spurt.
- Venous bleeding. Veins transport blood under low pressure. Blood coming from a vein will flow.
- Capillary bleeding. Capillaries also carry blood under low pressure. Blood coming from capillaries will ooze.

There are three main methods for controlling bleeding:

- Direct pressure
- Elevation
- Pressure points

Direct pressure and elevation will control bleeding in 95% of cases.

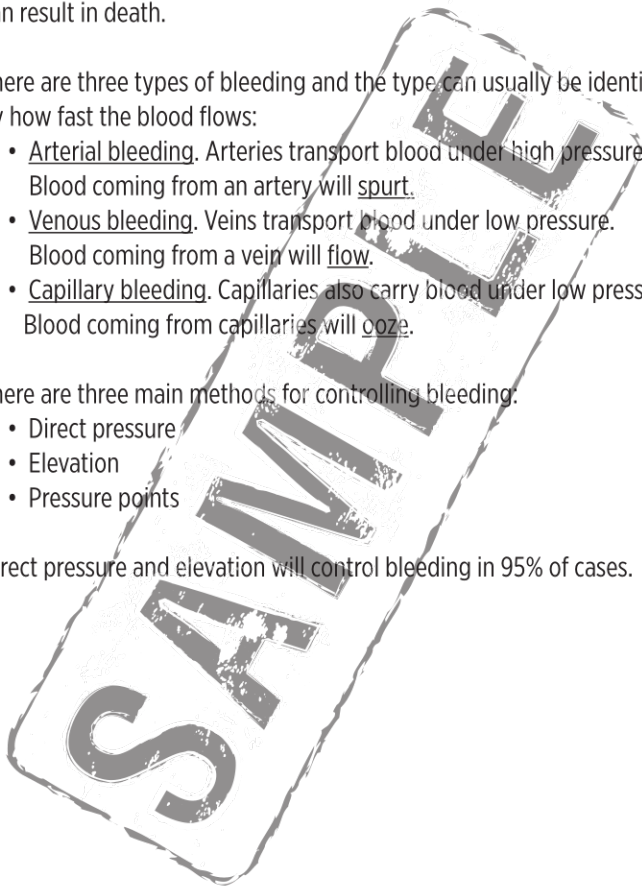

Disaster Medical Operations

Procedures for Controlling Bleeding

Method	Procedures
Direct Pressure	<p>Place direct pressure over the wound by putting a clean dressing over the wound and pressing firmly.</p> <p>Maintain pressure on the dressing over the wound by wrapping the wound firmly with a pressure bandage and tie with a bow.</p>
Elevation	<p>Elevate the wound above the level of the heart.</p>
Pressure Points	<p>Put pressure on the nearest pressure point to slow the flow of blood to the wound. Use the:</p> <ul style="list-style-type: none">• Brachial point for bleeding in the arm.• Femoral point for bleeding in the leg.• Popliteal point for bleeding in the lower leg <p>(See the figures on the following page for illustrations of these pressure points.)</p>

Direct pressure combined with elevation will address most bleeding.

Direct pressure and elevation can take 5 to 7 minutes to stop the bleeding completely. The use of a dressing and pressure bandage allows the rescuer to move on to the next victim.

A pressure bandage should be tied with a bow, so that it can be loosened—rather than cut—to examine the wound, and then re-tie. This procedure helps to conserve supplies and saves time. If the victim is turning blue or becoming numb below the bandage, then it should be loosened.

ELEVATION

Elevation can be used in combination with direct pressure. Elevate the wound above the level of the heart.

The body has great difficulty pumping blood against gravity; therefore, elevating a wound above the heart will decrease blood flow and loss of blood through the wound.

Disaster Medical Operations

Methods for Controlling Bleeding

The pressure points most often used are the:

- Brachial point in the arm
- Femoral point in the leg
- Popliteal point behind the knee

The pressure point to use depends on the location of the wound. The correct pressure point is between the wound and the heart.

The three main methods of controlling bleeding are:

- Direct pressure
- Elevation
- Pressure points.

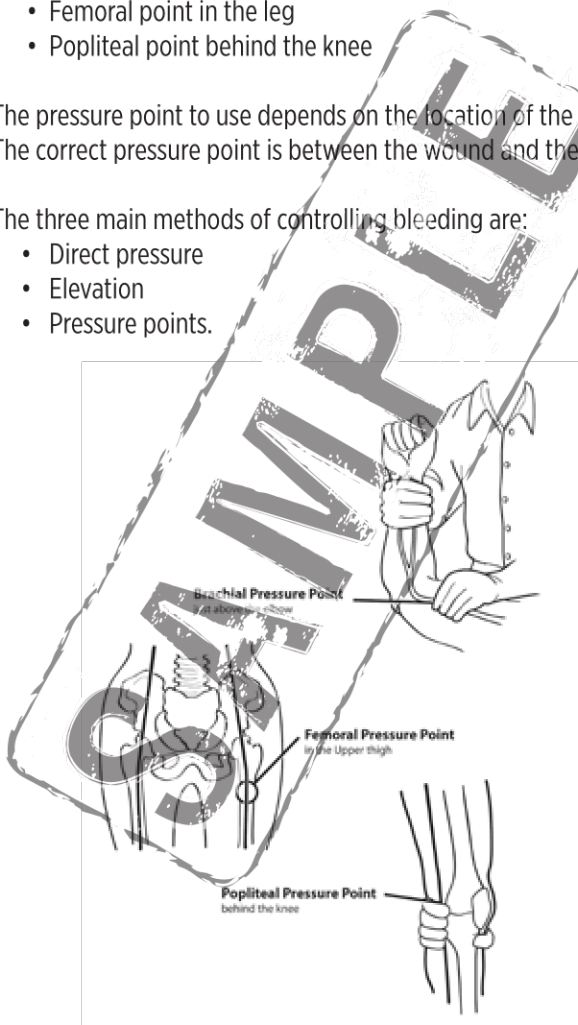

Burn Treatment

The skin has three layers:

- The epidermis, or outer layer of skin, contains nerve endings and is penetrated by hairs.
- The dermis, or middle layer of skin, contains blood vessels, oil glands, hair follicles, and sweat glands.
- The subcutaneous layer, or innermost layer, contains blood vessels and overlies the muscle and skin cells.

Depending on the severity, burns may affect all three layers of skin.

Medical

Burn Classifications

Classification	Skin Layers Affected	Signs
Superficial	<ul style="list-style-type: none">• Epidermis	<ul style="list-style-type: none">• Reddened, dry skin• Pain• Swelling (possible)
Partial Thickness	<ul style="list-style-type: none">• Epidermis• Partial destruction of dermis	<ul style="list-style-type: none">• Reddened, blistered skin• Wet appearance• Pain• Swelling (possible)
Full Thickness	<ul style="list-style-type: none">• Complete destruction of epidermis and dermis• Possible subcutaneous damage (destroys all layers of skin and some or all underlying structures)	<ul style="list-style-type: none">• Whitened, leathery or charred (brown or black)• Painful or relatively painless

Burn Treatment

Guidelines for treating burns:

- Remove the victim from the burning source. Put out any flames and remove smoldering clothing unless it is stuck to the skin.
- Cool skin or clothing, if they are still hot, by immersing them in cool water for not more than 1 minute or covering with clean compresses that have been soaked in cool water and wrung out. Cooling sources include water from the bathroom, kitchen, garden hose, soaked towels, sheets or other cloths. Treat all victims of full thickness burns for shock.
- Cover loosely with dry sterile dressings to keep air out and prevent infection.
- Wrap fingers and toes loosely and individually when treating severe burns to the hands and feet.
- Loosen clothing near the affected area. Remove jewelry if necessary, taking care to document what was removed, when and to whom it was given.
- Elevate burned extremities higher than the heart.
- Do not use ice. Ice causes vessel constriction.
- Do not apply antiseptics, ointments, or other remedies.
- Do not remove shreds of tissue, break blisters, or remove adhered particles of clothing. (Cut burned-in clothing around the burn.)

Infants, young children, older persons, and persons with severe burns are more susceptible to hypothermia. Rescuers should use caution when applying cool dressings on such persons. Do not cool more than 15 percent of the body surface area (the size of one arm) at once, to reduce the chances of hypothermia.

Hypothermia Treatment

Hypothermia is a condition that occurs when the body's temperature drops below normal. Hypothermia may be caused by exposure to cold air or water or by inadequate food combined with inadequate clothing and/or heat, especially in older people.

The primary signs and symptoms of hypothermia are:

- A body temperature of 95° Fahrenheit (37° Celsius) or less.
- Redness or blueness of the skin.
- Numbness accompanied by shivering.

In later stages, hypothermia will be accompanied by:

- Slurred speech.
- Unpredictable behavior.
- Listlessness.

Because hypothermia can set in within only a few minutes, you should treat victims who have been rescued from cold air or water environments by:

- Removing wet clothing.
- Wrapping the victim in a blanket or sleeping bag and covering the head and neck.
- Protecting against the weather.
- Providing warm, sweet drinks and food to conscious victims. Do NOT offer alcohol or massage.
- Placing an unconscious victim in the recovery position.
 - Place victim's arm that is nearest to you at a right angle against the ground, with the palm facing up.
 - Move the victim's other arm across his or her chest and neck, with the back of their hand resting against his or her cheek.
 - Grab a hold of the knee furthest from you and pull it up until the knee is bent and the foot is flat.
 - Position the victim's leg at a right angle against the floor so that the victim is lying on his or her side.
- Placing the victim in a warm bath if the victim is conscious.

Do not allow the victim to walk around even when he or she appears to be fully recovered. If the victim must be moved outdoors, you should cover the victim's head and face.

Fire Fighting

Deciding to use a Fire Extinguisher

A flowchart illustrates the decision-making process for determining whether to use a fire extinguisher. The decision is based on four questions.

If the answer to all questions is “yes,” CERT members should attempt to extinguish the fire.

If the answer to any question is “no,” CERT members should leave.

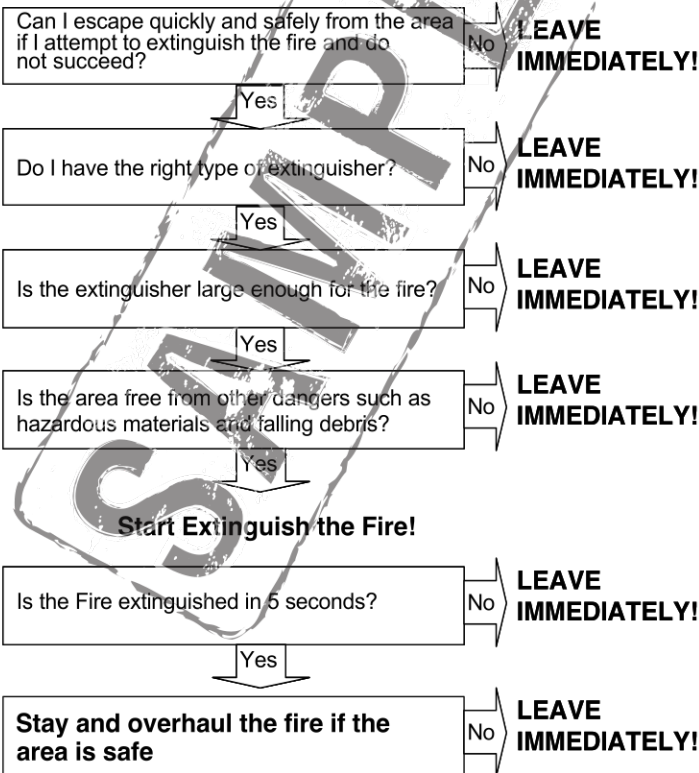

Fire Fighting

Elements Required for a Fire

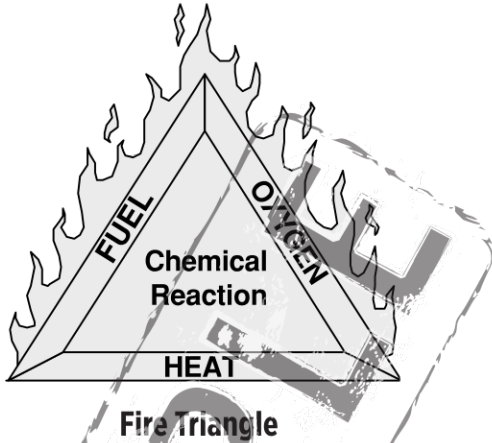

Fire

Fire Triangle:

- Fuel
- Oxygen
- Heat

Fire requires three elements to exist:

- Heat: Required to elevate the temperature of a material to its ignition point.
- Fuel: The fuel for a fire may be a solid, liquid, or gas. The type and quantity of the fuel will determine which method should be used to extinguish the fire.
- Oxygen: Most fires will burn vigorously in any atmosphere of at least 20 percent oxygen. Without oxygen, most fuels could be heated until entirely vaporized, yet would not burn.

Working together, these three elements, called the fire triangle, create a chemical exothermic reaction, which is fire. If any of these elements is missing or if any is taken away, fire will not occur or will extinguish.

Hazardous Materials

Hazardous materials are all around us and may be present regardless of the location or whether there are placards or other posted warnings. While hazardous materials often smell, sound, or look unusual, you may not be able to recognize something toxic. You should stay away from any unidentifiable substance and alert building managers or authorities.

Fire

Materials are considered hazardous if they have any of these characteristics listed below:

- Corrode other materials
- Explode or are easily ignited
- React strongly with water
- Are unstable when exposed to heat or shock
- Are otherwise toxic to humans, animals or the environment through absorption, inhalation, injection or ingestion

Hazardous materials include, but are not limited to:

- Explosives
- Flammable gases and liquids
- Poisons and poisonous gases
- Corrosives
- Nonflammable gases
- Oxidizers
- Radioactive materials

Hazardous Materials

Identifying Hazardous Materials in Transit

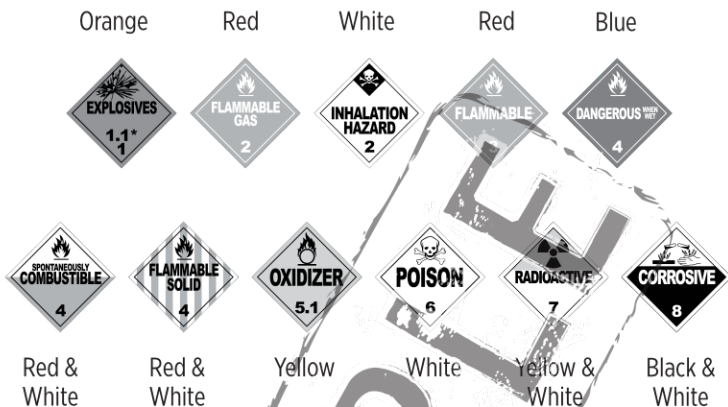

Fire

DOT Warning Placards

There are three ways that hazardous materials are marked and identified while in transit:

- The Department of Transportation (DOT) placards
- The United Nations (UN) system
- The North American (NA) warning placards

These placards can be on any vehicle, not only tankers. Keep in mind:

- No placard is required for less than 1,000 pounds of many hazardous materials.
- Certain hazardous materials (e.g., anhydrous ammonia) are placarded as a nonflammable gas for domestic transport but as a flammable gas for international transport.

Anhydrous ammonia is a flammable gas!

Sometimes drivers forget to change the placard when they change their cargo. CERT members should use extreme caution when approaching any vehicle in an accident. **ALWAYS APPROACH THE ACCIDENT OR SCENE FROM THE UP WIND DIRECTION (WIND AT THE BACK OF THE CERT MEMBER).**

Deciding to Attempt Rescue

The decision to attempt a rescue should be based on three factors:

- The risks involved to the rescuer
- The overall goal of doing the greatest good for the greatest number of people
- Resources and manpower available

Goals of search and rescue operations are to:

- Rescue the greatest number of people in the shortest amount of time
- Get the walking wounded and ambulatory victims out first
- Rescue lightly trapped victims next
- Keep the rescuer safe

Search and Rescue Resource Planning Questions

Resource	Planning Questions
Personnel	<ul style="list-style-type: none">• How many trained CERT members are available for this operation?• Who lives and/or works in the area?• During which hours are these people most likely to be available?• What skills or hobbies do they have that might be useful in search and rescue operations?• What might be the most effective means of mobilizing their efforts?
Equipment	<ul style="list-style-type: none">• What equipment is available locally that might be useful for search and rescue?• Where is it located?• How can it be accessed?• On which structures, or types of structures, might it be most effective?
Tools	What tools are available that might be useful for lifting, moving, or cutting disaster debris?

CERT Search and Rescue Size-up Checklist

Step 1: Gather Information

Time

- Does the time of day or week affect search and rescue efforts? How?

Type of Construction and Terrain

- What type(s) of structure(s) is(are) involved?
- What type(s) of construction is(are) involved?
- What type(s) of terrain is(are) involved?

Occupancy

- Are the structures occupied? By how many people?
- Are there special considerations (e.g. children, elderly)?
If yes, what are the special considerations?

Weather

- Will weather conditions affect your safety? How?
- Will weather conditions affect the search and rescue situation? If yes, how will the search and rescue situation be affected?

Hazards

- Are hazardous materials involved? Which ones? If yes, at what location?
- Are any other types of hazards likely to be involved? What are they?

Step 2: Assess and Communicate the Damage

Take a lap around the building.

- Is the damage beyond the CERT team's capability?
If yes, what special requirements or qualifications are required?
- Have the facts and the initial damage assessment been communicated to the appropriate persons(s)?

Step 3: Consider Probabilities

- Is the situation stable?
- Is there great risk or potential for more disaster activity that will impact personal safety? If yes, what are the known risks?
- What else could go wrong?

Step 4: Assess Your Own Situation

- What resources are available with which you can attempt the search and rescue?
What equipment is available?

Step 5: Establish Priorities

- Can a search and rescue operation be safely attempted by CERT members?
If no, do *not* attempt a search and rescue.
- Are there other, more pressing needs at the moment? If yes, list.

Step 6: Make Decisions

- Where will deployment of available resources do the most good while maintaining an adequate margin of safety?

Step 7: Develop a Plan of Action

- Determine how personnel and other resources should be deployed.

Step 8: Take Action Plan

- Put the plan into effect.

Step 9: Evaluate Progress

- Continually size up the situation to identify changes in the scope of the problem, the safety risks, and resource availability.

Light Search and Rescue

Rescue Lifts and Carries

There are several types of lifts and carries. For example, if the rescuer is physically able and the victim is small, he or she may use the One Person Arm Carry to lift and carry the victim by:

- Reaching around the victim's back and under the knees.
- Lifting the victim while keeping the rescuer's back straight and lifting with the legs.



One Person Arm Carry

One Person Arm Carry, which shows the rescuer holding the victim around the victim's back and under the knees.

Note: Consider the size of the victim and the distance he or she needs to be carried before using this carry. If safety and time permit, you should not use lifts or drags to remove victims when head or spinal injury is suspected. In such cases, the spine must be stabilized using a backboard. Doors, tables, and similar materials can be used as improvised backboards. The backboard must be able to carry the person and proper lifting techniques must be used. When moving victims, rescuers must use teamwork and communication and keep the victim's spine in a straight line. Remember, rescuer safety and the condition of the building will dictate the approach.

Light Search and Rescue

Rescue Lifts and Carries

Another way for a single rescuer to lift a victim safely is by using the One Person Pack Strap Carry. Using this method, the rescuer should follow the steps outlined below:

- Step 1: Stand with your back to the victim.
- Step 2: Place the victim's arms over your shoulders and grab the victim's hands in front of your chest.
- Step 3: Hoist the victim by bending forward slightly, until his or her feet just clear the floor.

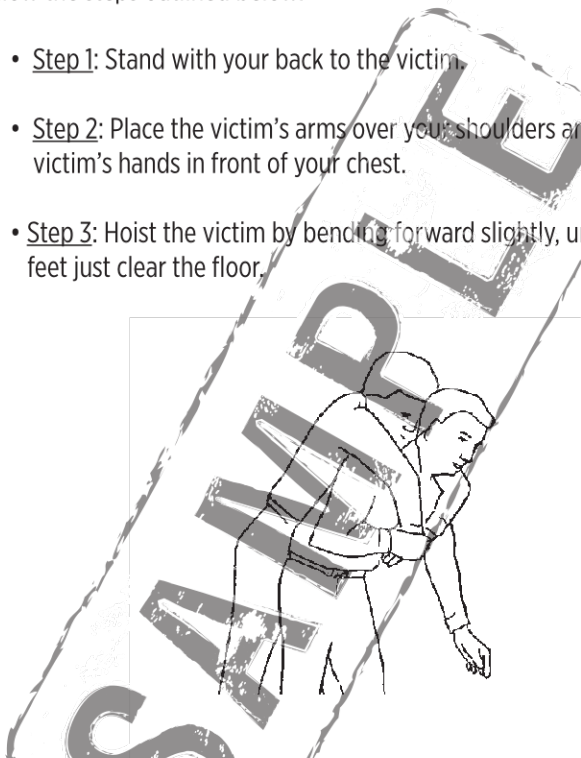

One Person Pack Strap Carry

One Person Pack Strap Carry, in which the rescuer places the victim's arms over his or her shoulders and grabs the victim's hands over his or her chest, then hoists the victim by bending over slightly.

Light Search and Rescue

Rescue Lifts and Carries

Victim removal is easier when multiple rescuers are available. With two rescuers, a victim may be removed using a two person lift:

- Rescuer 1: Squat at the victim's head and grasp the victim from behind around the midsection. Reach under the arms and grasp the victim's forearms.
- Rescuer 2: Squat between the victim's knees, facing either toward or away from the victim. Grasp the outside of the victim's legs at the knees.
- Both Rescuers: Rise to a standing position, keeping back straight and lifting with the legs. Walk the victim to safety.



Two Person Carry

Two Person Carry in which rescuer 1 squats at the victim's head and grasps the victim from behind at the midsection. Rescuer 2 squats between the victim's knees, grasping the outside of the knees. Both rescuers rise to a standing position.

Light Search and Rescue

Rescue Lifts and Carries

Two rescuers can also remove a victim by seating him or her on a sturdy, non-swivel chair:

- Rescuer 1: Facing the back of the chair, grasp the back uprights.
- Rescuer 2: Facing away from the victim, reach back and grasp the two front legs of the chair.
- Both Rescuers: Tilt the chair back, lift and walk out.

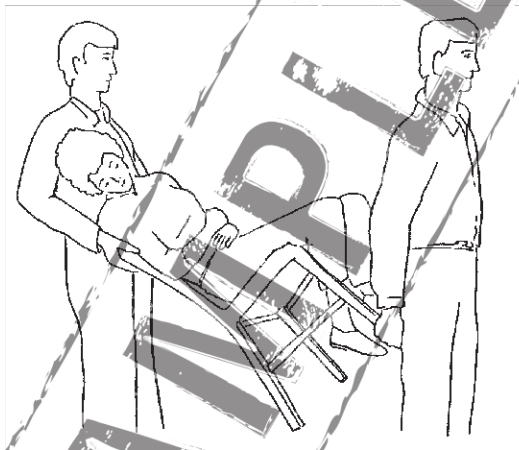

Chair Carry

Chair Carry in which the victim is placed in a sturdy, non-swivel chair and tilted backward as rescuers lift the victim. This carry requires two rescuers. If possible, secure victim to the chair. Note that if rescuers will need to carry the victim over uneven surfaces, such as stairs, the rescuers must face each other. Be aware of any head, neck or back injuries. If injuries are suspected, do not move the victim!

Light Search and Rescue

Rescue Lifts and Carries

Rescuers can also drag a victim out of a confined area by grasping either the shoulders or by the feet and pulling across the floor.

However, unless there is no other way to remove the victim and the victim's removal is time critical, you should not use this drag when debris may cause additional injury.

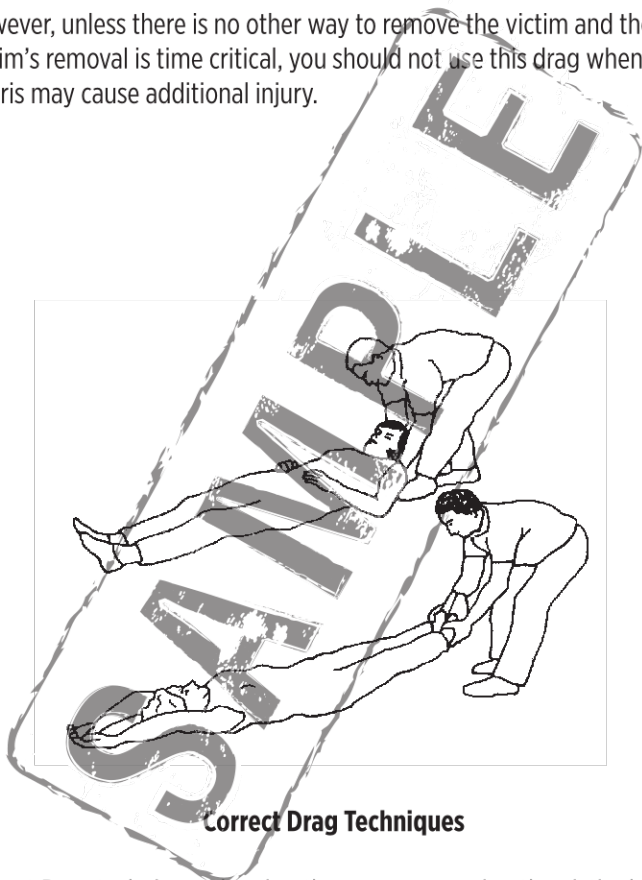

SAR

Correct Drag Techniques

Correct Drag technique, showing the rescuer grasping the victim by either the feet or shoulders and dragging him or her clear of the hazard. Be aware of any head, neck or back injuries. If injuries are suspected, do not move the victim!

Light Search and Rescue

Rescue Lifts and Carries

A variety of materials—such as blankets—can be used as improvised stretchers.

When necessary, one rescuer can use the blanket drag by following these steps:

- Step 1: Wrap the victim in a blanket.
- Step 2: Squat down and grasp an edge of the blanket.
- Step 3: Drag the victim across the floor.

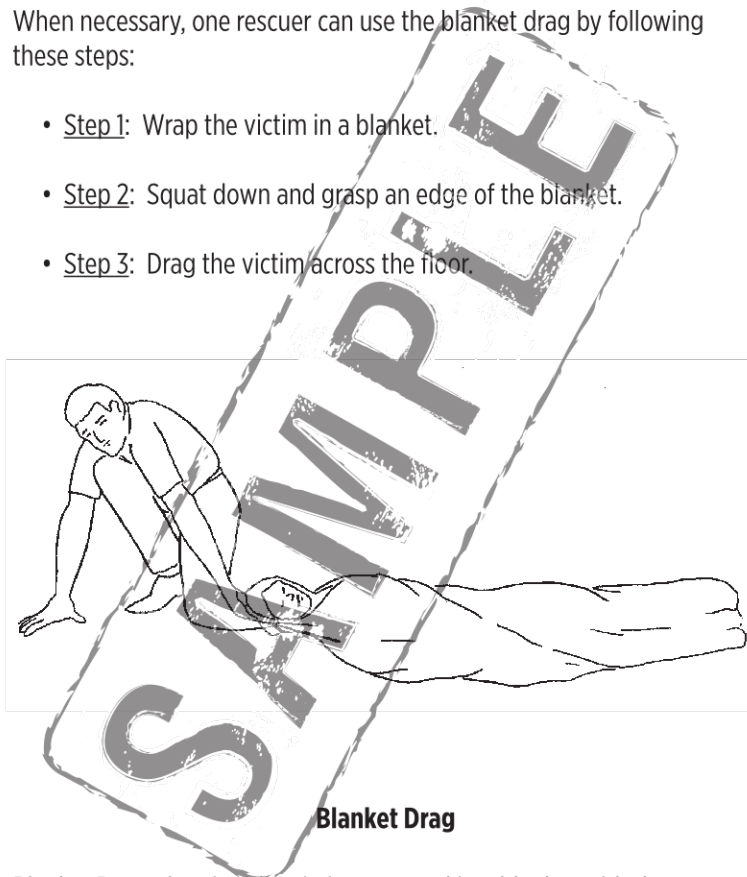

Blanket Drag

Blanket Drag, showing the victim wrapped in a blanket with the rescuer squatting at the victim's head. The rescuer grasps the blanket behind the victim's head and drags him or her clear of the hazard. Be aware of any head, neck or back injuries. If injuries are suspected, do not move the victim!

Expedient Flood Training

Key Points

Filling Sandbags -

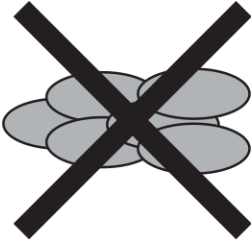

Yes!



Do not overfill sandbags - fill bags only half-full for better stacking!

Flood

Dig a Key Trench -

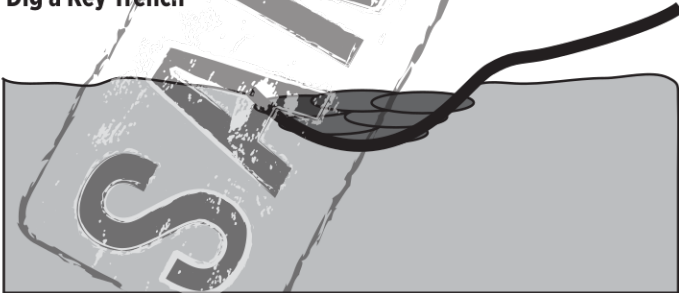

Follow the survey line and dig a key trench 4 to 6 inches deep and two sand bags wide. Anchor poly securely in the trench.

Expedient Flood Training

Key Points

Stack Sandbags -

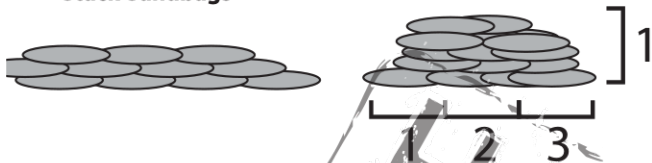

Do not overfill sandbags - fill bags only half-full for better stacking!

Cap Poly -



Once the appropriate levee height has been achieved, cap the poly to hold it in place.

Manholes

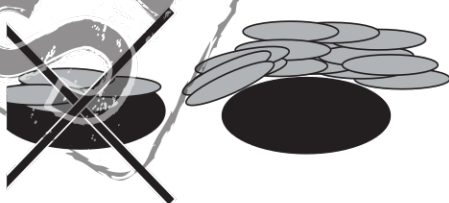

Ring manholes with sandbags and allow the water to seek its own level. **DO NOT** place sandbags on manhole covers!

Expedient Flood Training

Key Points

Sand Boils -

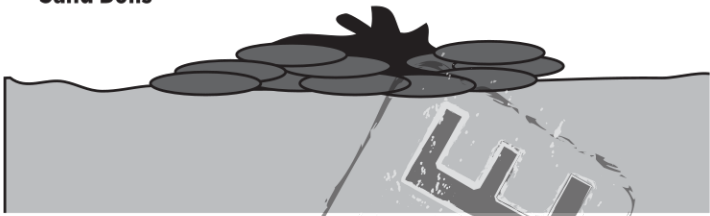

Ring sand boils with sandbags to reduce water flow and stop sand & soil movement.

DO NOT attempt to completely stop the water flow!

Use **COMMON SENSE!**

Flood

Foundations -

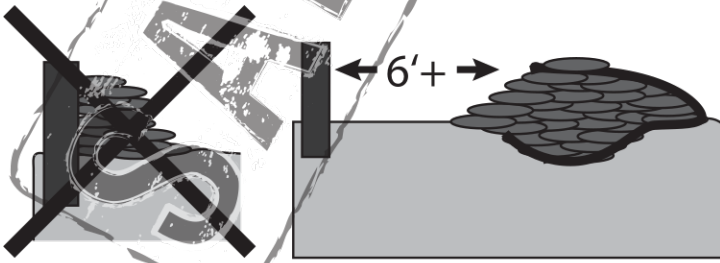

Keep at least six feet from basement and foundation walls!

Expedient Flood Training

Important Points

- Use extreme caution around electrical equipment and machinery.
- Always lift with your legs, not your back.
- Properly care for all wounds and injuries, no matter how minor.
- Dress in layers and appropriately for the weather.
- Drink plenty of fluids and eat regularly.
- Do not walk behind construction equipment.
- Plan an emergency escape route.
- Travel only when necessary and in groups of three.
- Use extreme care when walking in flooded areas.
- Be careful around foundations, watch for cave-ins.
- Report broken gas lines immediately!
- Wash your hands before eating and follow basic sanitary procedures.
- Stop immediately if you feel dizzy, have chest pain, shortness of breath or pain down your left arm.
- Seek immediate medical attention!

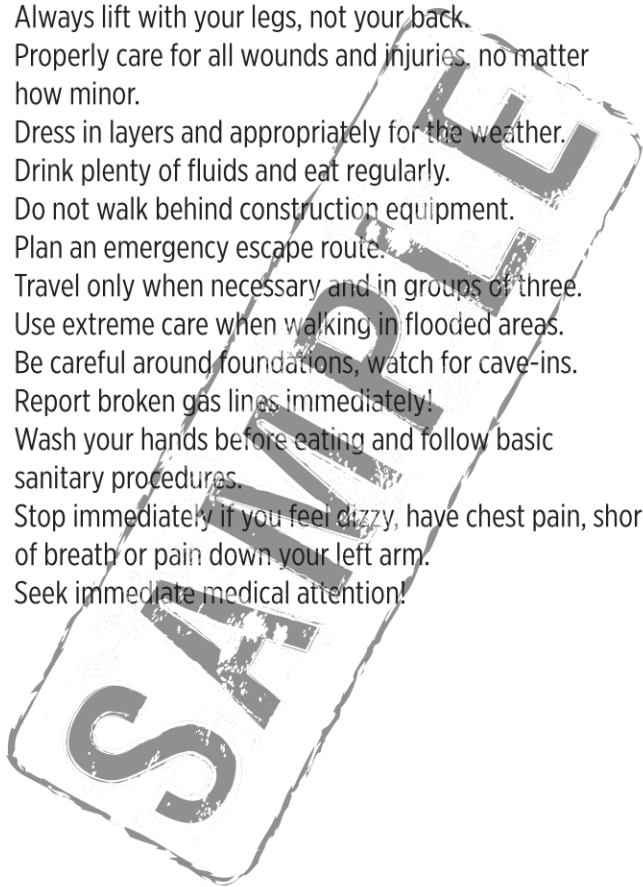

Floods

“Rule number one” is to move quickly to higher ground. Flood waters can carry debris, scour soil and asphalt, and trigger landslides. Even shallow-depth, fast-moving waters of 24 inches can produce enough force to carry away a vehicle, and six inches of swiftly moving water can knock someone off his or her feet.

If you must evacuate:

- Do not walk, swim, or drive through floodwaters. Learn and practice driving the local flood evacuation routes. They have been selected because they are safe and provide the best means of escaping flood waters.
- Stay off bridges over fast-moving water. Fast-moving water can wash bridges away without warning, especially if the water contains heavy debris.
- Keep away from waterways. If you are driving and come upon rapidly rising waters, turn around and find another route. Move to higher ground away from rivers, streams and creeks.
- Pay attention to barricades. Local responders place barricades to warn of flooding ahead or to direct traffic safely out of the area. Never drive around barricades.
- Avoid storm drains and irrigation ditches. During a flood, storm drains and irrigation ditches fill quickly with fast-moving water. Walking in or near storm drains or irrigation ditches is nearly a sure way to drown.
- Keep family together. As always, family is most important even in a flood. Do not lose track of family members.

Precautions to follow after a flood:

- Stay out of flooded areas. Flooded areas remain unsafe. Entering a flooded area places you -and the individuals who may need to rescue you- at risk.
- Reserve the telephone for emergencies only. Phone lines (both land line and cellular) will be busy following a flood. A non-emergency call may prevent an emergency call from getting through. It is best not to use the phone unless it is necessary.
- Avoid driving, except in emergencies. Reserve the roads for those who must evacuate and for emergency vehicles.
- Wait for authorities to issue a clear message that it is safe to return to evacuated areas.
- Be aware that snakes and other animals may be in your house in the aftermath of a flood. Look for loose boards and dark spaces and investigate with care.

Earthquakes

Earthquakes are classified, based on the Richter Scale as:

- Small: 5.0-5.9
- Moderate: 6.0-6.9
- Major: 7.0-7.9
- Great: 8.0 or greater

The Richter Scale has a logarithmic base, so each increment on the scale is multiplied by a factor of 10. For example, an earthquake of magnitude 8.6 would not be twice as violent as one of 4.3, but rather would be more than 10,000 times worse.

To stay safe during an earthquake, you should:

- Drop, cover and hold.
- If indoors, stay there until shaking stops.
- If outdoors, find a spot away from buildings, trees, street lights, power lines and overpasses.
- If in a vehicle, pull over at a clear location free of hazards and stop.

After you have taken care of yourself, you should:

- Look for and extinguish small fires.
- Clean up spills.
- Inspect the home for damage.
- Help neighbors who may require assistance.
- Tune to the Emergency Alert System (EAS).
- Expect aftershocks. (Aftershocks often occur minutes, days, or weeks following an earthquake. When aftershocks occur, drop, cover and hold).

Fires and Wildfires

There are three classes of wildfires:

- Surface fire: The most common type of fire. Burns along the floor of a forest, moving slowly and killing or damaging trees.
- Ground fire: Usually started by lightning and burns on or below the forest floor in the humus layer down to the mineral soil.
- Crown fire: Spreads rapidly by wind and moves quickly by jumping along the tops of trees.

Wildfires often begin unnoticed and many fires spread quickly, igniting brush, trees and homes.

Keep in mind the following measures to help prevent damage from wildfires:

- Listen for emergency information on radio or television stations or EAS. If advised to evacuate, do so immediately.
- Confine pets to one room or arrange for them to stay with a friend or relative.
- Move flammable furniture to the center of the home, away from windows and sliding glass doors.
- Remove flammable drapes and curtains. Close venetian blinds and noncombustible window treatments.
- Close all doors and windows to reduce air flow.

If trapped by a wildfire, you should try to find a body of water to crouch in.

If possible, cover the head and upper body with wet clothing. If a body of water is not accessible, look for shelter in a clear area or within a rock bed. Breathe the air close to the ground, preferably through a dry cloth.

After a wildfire, you should:

- Use caution when reentering the area after a wildfire.
- Inspect the roof immediately and extinguish sparks or embers that could reignite the fire.
- Have propane or heating oil tanks inspected by the supplier before using.
- Check the stability of trees around the home.
- If there is no power, check the main breaker.

Before cleaning property after a fire you should take the following precautions:

- Wet down debris to reduce dust in the air.
- Using a N-95 mask with nose clip.
- Wearing coveralls and leather gloves to protect the hands.
- Check with local authorities before disposing of household hazardous materials.

Excessive Heat

Under normal conditions, the body's internal thermostat produces perspiration that evaporates and cools the body. In abnormal heat and high humidity, however, evaporation is slowed and the body must work extra hard to maintain its normal temperature. The elderly, the very young, and those who are disabled are at risk from extreme heat. Also, because men sweat more than women, they are more likely to have difficulty with extreme heat as a result of dehydration.

The risks associated with a heat wave can include:

- Heat cramps: Muscular pains and spasms resulting from heavy exertion. Heat cramps are often the first signal that the body is suffering from excessive heat.
- Heat exhaustion: A form of mild shock that typically occurs when people exercise heavily or work in a hot, humid place where body fluids are lost through heavy sweating.
- Heat/Sun stroke: **A LIFE-THREATENING CONDITION** in which the victim's temperature control system that produces sweat to cool the body stops working. The body temperature can rise to the extent that brain damage and death may result if the body is not cooled quickly.

Do the following during a heat wave:

- Seek air conditioning.
- Avoid strenuous activities.
- Wear lightweight, light-colored clothing. Protect the face and head by wearing a wide-brimmed hat.
- Check on family members and neighbors.
- Drink plenty of fluids. Dehydration can occur quickly and can be unnoticed or mistaken for other illnesses.
- Take frequent breaks. Taking frequent breaks and seeking shade allows the body to cool down.

However, persons who are on fluid-restrictive diets (e.g., those with kidney disease) should consult their doctors before increasing fluid intake.

Hurricanes

Category	Barometric Pressure (inches)	Wind Speed (Miles per Hour)	Storm Surge (feet)
I - Minimal	Above 28.94	74 - 95	4 - 5
II - Moderate	28.50 - 28.91	96 - 110	6 - 8
III - Extensive	27.91 - 28.47	111 - 130	9 - 12
IV - Extreme	27.17 - 27.88	131 - 155	13 - 18
V - Catastrophic	Less than 27.17	More than 155	More than 18

During a hurricane:

- Stay indoors. Even Category 1 hurricanes are dangerous. Stay indoors and listen to EAS for up-to-date information.
- If advised to shelter:
 - Take the family disaster supply kit.
 - Go to an interior “safe” room without windows, if possible.
 - Stay in the safe room and listen to EAS for additional instructions.
- Stay away from floodwaters. Go to a higher level, if necessary.
- Be aware of the “eye.” The “eye” of a hurricane is typically 20 to 30 miles wide in relation to the storm, which may have a diameter of 400 miles. During the “eye,” there are very few clouds, but it’s important to remember the storm is not over.
- Be alert for tornadoes. Tornadoes are frequently associated with hurricanes, and are most common in the right-front quadrant of the storm.

After a hurricane:

- Do not reenter the area until it is declared safe.
- Use a flashlight to inspect for damage.
- Stay away from downed power lines.
- Turn off utilities, if necessary.
- Wear protective clothing, sunscreen, and bug repellent.
- Be aware that lost pets may be scared and more inclined to bite.
- Be aware of traffic hazards.
- Check on neighbors.
- Reserve the telephone for emergency use.
- Listen to Emergency Alert System (EAS) for updated information.

Landslides and Mud Flows

Landslides tend to worsen the effects of flooding that often accompany them. In areas that have been burned by forest and brush fires, a lower threshold of precipitation may initiate landslides.

While some landslides move slowly and cause damage gradually, others move so rapidly that they can destroy property and take lives suddenly and unexpectedly.

Areas that are generally prone to landslides include:

- Existing old landslides.
- The bases of steep slopes.
- The bases of drainage channels.
- Developed hillsides where leach-field septic systems are used.

Debris flows - sometimes referred to as mud slides, mud flows, lahars, or debris avalanches are common types of fast-moving landslides. Flows usually start on steep hillsides as shallow landslides that accelerate to speeds that are typically about 10 miles per hour, but can exceed 35 miles per hour.

The consistency of debris flows range from watery mud to thick, rocky mud that can carry away items such as boulders, trees and cars. When the flows reach flatter ground, the debris spreads over a broad area.

The most destructive types of debris flows are those that accompany volcanic eruptions.

Severe Thunderstorms

While all thunderstorms are dangerous, the National Weather Service (NWS) defines a severe thunderstorm as one that meets at least one of the following conditions:

- Produces hail at least three-quarters of an inch in diameter.
- Has winds of 58 miles per hour or greater.
- Produces a tornado.

The risks associated with severe thunderstorms include:

- Lightning.
- Hail. Pets and livestock are particularly vulnerable to hail.
- Down bursts and straight-line winds. Thunderstorms can produce winds as high as 150 miles per hour—strong enough to flip cars, vans and trucks.
- Flash floods. Heavy rain from thunderstorms can cause flash flooding.
- Tornadoes. Some thunderstorms may spawn tornadoes.

What to do if caught in a severe thunderstorm:

- Avoid water sources.
- Avoid using the telephone. Cell phones are considered safe to use indoors, though there is some risk when used outdoors during a storm.
- Avoid contact with metal surfaces.
- Avoid flooded roadways.
- Listen to EAS.
- Avoid storm-damaged areas.
- Watch for fallen power lines and trees.
- Seek shelter in a substantial, permanent, enclosed structure.
- Avoid unprotected shelters, such as golf carts and baseball dugouts. Isolated shelters in other open areas are targets for lightning. If there are no permanent shelters within reach, take shelter in a car. Pull safely to the side of the road. Keep all windows closed and do not touch anything that is metal. If in the woods, find an area that is protected by low trees (not a single tall tree in the open). As a last resort, go to a low-lying area, away from trees, poles, and metal objects. Squat low to the ground, and place your hands on your knees with your head between them. Make as small a target as possible.
- Do not lie flat on the ground.
- Avoid natural lightning rods, such as trees, golf clubs, tractors, fishing rods, and camping equipment. Lightning is attracted to these items.

Tornadoes

Wind Damage Level	Wind Speed	Damage
F0	Up to 72 mph	Light
F1	73-112 mph	Moderate
F2	113-157 mph	Considerable
F3	158-206 mph	Severe
F4	207-260 mph	Devastating
F5	261 mph or Greater	Incredible

During a Tornado:

- Keep all windows and doors closed. Damage often occurs when wind gets inside a home. Houses do not explode because of air pressure differences.
- Go immediately to an underground shelter or tornado-safe room, or interior room or hallway on the lowest floor.
- Put as much shielding material (such as furniture, blankets, bike helmets, etc.) as you can around you.
- Listen to EAS or NOAA Weather Radio for current emergency information and instructions.
- If you are driving and see a tornado go to a nearby sturdy building and seek an area on the lowest level, without windows. If there are no buildings nearby, get out and away from the vehicle and lie down in a low spot on the ground. Protect the head and neck.

Following a tornado, citizens should continue listening to EAS or NOAA weather radio for updated information and instructions. As with many other hazards, post-tornado actions include:

- Avoid fallen power lines or broken utility lines and immediately report those you see.
- Stay out of damaged areas until told that it is safe to enter.
- Stay out of damaged buildings until inspected and deemed safe by authorities.
- Use a flashlight to look for damage and fire hazards and document damage for insurance purposes.
- Turn off utilities, if necessary.
- Reserving the telephone for emergencies.

Tsunamis

If a strong coastal earthquake occurs:

- Drop, cover and hold. You should protect yourself from the earthquake first.
- When the shaking stops, gather your family members and evacuate quickly. Leave everything else behind. A tsunami could occur within minutes. Move quickly to higher ground away from the coast up to 2 miles inland.
- Avoid downed power lines, and stay away from buildings and bridges from which heavy objects might fall during an aftershock.
- If you are in a tsunami risk area and you hear an official tsunami warning or detect signs of a tsunami, evacuate at once.
- Follow instructions issued by local authorities.
- If a warning is issued get to higher ground as far inland as possible.
- Listen to a NOAA Weather Radio or Coast Guard emergency frequency station for updated emergency information.
- Return home only after local officials tell you that it is safe.
- If you are out on a boat when the warning is issued, move as far out from the coast as possible.

As with many other hazards, post-tsunami actions include:

- Avoid fallen power lines or broken utility lines and immediately report those you see.
- Stay out of damaged areas until told that it is safe to enter. The risk of contamination and disease is very high.
- Stay out of damaged buildings until inspected and deemed safe by authorities.
- Use a flashlight to look for damage and fire hazards, and document damage for insurance purposes.
- Turn off utilities, if necessary.
- Reserve the telephone for emergencies.

Volcanoes

Volcanic hazards include:

- Toxic gases
- Lava and pyroclastic flows
- Landslides
- Earthquakes
- Explosive eruptions

Volcanic ash is fine, glassy rock fragments that can affect people and equipment hundreds of miles away from the cone of the volcano.

Volcanic ash will:

- Cause severe respiratory problems.
- Diminish visibility.
- Contaminate water supplies.
- Cause electrical storms.
- Disrupt the operation of all machinery.
- Collapse roofs.
- Contaminate air filtration systems in homes and vehicles.

During a Volcanic Eruption:

- Follow evacuation orders.
- Avoid areas downwind and river valleys downstream of the volcano.
- If outside, protect yourself from ash fall.
- Protect yourself from breathing ash, this can done by placing a wet or dry cloth over your mouth and nose and proceeding inside immediately.
- Be prepared for accompanying hazards.

After an Eruption:

- Stay away from all volcanic ash areas. The fine, glassy particles of volcanic ash will increase the health risk to children and people with existing respiratory conditions such as asthma, chronic bronchitis or emphysema.
- Avoid driving in heavy ash fall. Driving will stir up volcanic ash that can clog engines and stall vehicles. Moving parts, including bearings, brakes and transmissions can be damaged from abrasion.
- If you have a respiratory ailment, avoid contact with any amount of ash. Stay indoors until local health officials advise that it is safe to go outside.

Winter Storms

Snow

The different kinds of snow fall include:

- **Blizzards:** Accompanied by winds of 35 mph or more with snow and blowing snow, reducing visibility to less than $\frac{1}{4}$ mile.
- **Blowing snow:** Wind-driven snow that reduces visibility. Blowing snow may be falling snow and/or snow on the ground picked up by the wind.
- **Snow squalls:** Brief, intense snow showers accompanied by strong, gusty winds. Accumulation may be significant.
- **Snow showers:** A short duration of moderate snowfall. Some accumulation is possible.

Ice

The different kinds of ice include:

- **Sleet:** Raindrops that freeze into ice pellets before reaching the ground are called sleet. Sleet usually bounces and does not stick to objects. Sleet, however, can accumulate like snow and cause a hazard to motorists.
- **Freezing rain:** Rain that falls onto surfaces with temperatures below freezing, causing it to freeze to those surfaces, is called freezing rain. Even small accumulations of ice can cause a significant hazard.
- **Ice storm:** Occurs when freezing rain falls and freezes immediately on impact. Communications and power can be disrupted for days.

Cold

When talking about cold, you should consider:

- **Wind chill:** Wind chill is not the actual temperature, but rather how wind and cold feel on exposed skin. As the wind increases, heat is carried away from the body at a faster rate, driving down the body's temperature.
- **Frostbite:** Frostbite is damage to body tissue caused by extreme cold and resulting in a loss of feeling and a white or pale appearance in extremities. Frostbite victims require immediate medical treatment. If you must wait for help, slowly re-warm the affected areas.
- **Hypothermia:** Hypothermia occurs when the body temperature drops below 95 degrees Fahrenheit. If you suspect hypothermia, take the victim's temperature. If it is below 95 degrees Fahrenheit, seek medical care immediately! If medical care is not available, warm the person slowly, starting with the body core. Warming the arms and legs first drives cold blood toward the heart and can lead to heart failure. Dress the person in dry clothing and wrap him or her in a warm blanket, covering the head and neck. Do not provide alcohol, drugs, coffee or any hot beverage or food. Warm broth should be the first food offered.

Nuclear Power Plants

The area affected by radioactive material release is determined by:

- The amount of radiation released from the plant.
- Wind direction and speed.
- Weather conditions.

Hazards

The major hazards to people in the vicinity of the radiation plume include:

- Radiation exposure to the body from the cloud and particles on the ground.
- Inhalation of radioactive materials.
- Ingestion of radioactive materials.

Exposure can be minimized by:

- Time. Limit your time exposed to radioactive material. Most radioactivity loses its strength fairly quickly. In a nuclear power plant accident, local authorities will monitor any release of radiation and determine when the threat has passed.
- Distance. The more distance between you and the source of the radiation, the better. In a serious nuclear power plant accident, local authorities will call for an evacuation to increase the distance between you and the radiation. (Evacuation also reduces the period of time of exposure.)
- Shielding. The more heavy and dense material between you and the source of the radiation, the better. This is why local authorities could advise you to remain indoors if an accident occurs. In some cases, the walls in your home would be sufficient shielding to protect you. You should shelter in an area away from exterior doors and windows when possible.

Nuclear Emergency Terms:

- Notification of Unusual Event: A small problem has occurred at the plant. No radiation material release is expected. Federal, State, and county officials will be told right away. No action on your part will be necessary.
- Alert: A small problem has occurred, and small amounts of radiation material could leak inside the plant. This will not affect you, and you should not have to do anything.
- Site Area Emergency: A more serious problem has occurred, and small amounts of radiation material could leak from the plant. If necessary, State and County officials will act to assure public safety. Area sirens may be sounded. Listen to your radio or television for safety information.
- General Emergency: This is the most serious problem. Radiation material could leak outside the plant and off the plant site. The sirens will sound. Tune to your local radio or television station for emergency information reports. State and county officials will act to protect the public. Be prepared to follow instructions promptly.

Pandemic Influenza

In a disaster environment, food and water are often the most vulnerable to failure and are often the first supplies to be depleted. A pandemic event would be no different. To prepare for the possibility that access to fresh food and water may be limited, the Centers for Disease Control and Prevention (CDC) recommends keeping a **TWO-WEEK SUPPLY** of non-perishable food and water available at all times.

Food

- Store two weeks of non-perishable food.
- Select foods that do not require refrigeration, preparation (including the use of water), or cooking.
- Ensure that formulas for infants and any child's or older person's special nutritional needs are a part of your planning.

Water

- Store two weeks of water.
- 1 gallon of water per person per day (2 quarts for drinking, 2 quarts for food preparation/sanitation), in clean plastic containers.
- Avoid using containers that will decompose or break, such as plastic milk jugs or glass bottles.

These steps may help prevent the spread of respiratory illnesses like flu:

- Cover your nose and mouth with a tissue when you cough or sneeze. Throw the tissue away immediately after you use it.
- Wash your hands often with soap and water, especially after you cough or sneeze. If you are not near water, use an alcohol-based (60-95%) hand cleaner.
- Avoid close contact with people who are sick. When you are sick, keep your distance from others to protect them from getting sick.
- If you get the flu, stay home from work, school and social gatherings. In this way you will help prevent others from catching your illness.
- Try not to touch your eyes, nose or mouth. Germs often spread this way.
- Stay away from crowds whenever possible.

Terrorism — See page 59

ICS Command Function Organization Chart

INCIDENT COMMAND SYSTEM

Basic ICS structure for CERT is established by the person who arrives first on the scene. This person becomes the Incident Commander/Team Leader (IC/TL). Initially, the IC/TL may handle all of the command positions of ICS but, as the incident evolves, he or she may assign personnel as needed to the four ICS Command Functions:

- Operations Section Chief
- Logistics Section Chief
- Planning Section Chief
- Finance/Administration Section Chief

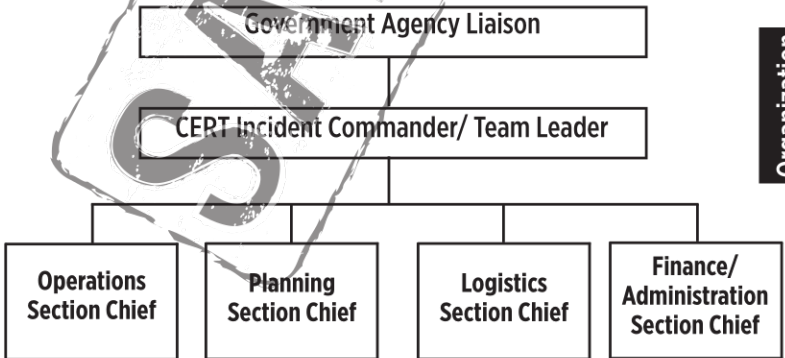

CERT Organization

CERT Incident Commander/Team Leader

- Provides overall leadership for incident response
- Ensures incident safety
- Establishes incident objectives
- Is responsible for ALL functions until delegated
- Delegates authority to others
- Provides information to internal and external parties
- Establishes and maintains liaison with other responders (e.g. fire, law enforcement, public works, other CERTs)
- Takes direction from agency official

Operations Section Chief

- Directs and coordinates all incident tactical operations
- Typically one of the first functions to be assigned

Planning Section Chief

- Tracks resource status (e.g., number of CERT members who have “reported for duty”)
- Tracks situation status
- Prepares the Team’s action plan
- Develops alternative strategies
- Provides documentation services

Logistics Section Chief

- Provides communications
- Provides food and medical support to Team members
- Manages supplies and facilities

Finance and Administration Section Chief

- Contract negotiation and monitoring
- Timekeeping
- Cost analysis
- Compensation for injury or damage to property

Finance and Administration is a function in the formal Incident Command System; however, CERTs will have very limited need, if any, for this function.

CERT Operations

Based on the principles of ICS, CERTs follow these protocols:

- Each CERT must establish a command structure.
- The CERT Incident Command/Team Leader (IC/TL) directs team activities. During activation for a disaster, the first person at the predesignated staging area assumes this responsibility. The initial IC/TL may hand off this role to a predesignated leader when that person arrives.
- The location established by the CERT IC/TL as the central point for command and control of the incident is called the Command Post for the CERT. The IC/TL stays in the Command Post. If the IC/TL has to leave, the responsibility of IC/TL must be delegated to someone in the Command Post.

Using ICS structure, CERT members are assigned to assist with a range of functions:

- Logistics - managing resources, service, and supplies
- Planning/Intelligence - collecting and displaying information; collecting and compiling documentation
- Operations - conducting fire suppression, medical operations, search and rescue

In all situations, each unit assigned must have an identified leader to supervise tasks being performed, to account for team members, and to report information to his or her designated leader.

In all situations, a manageable span of control is three to seven team members reporting to their designated leader.

CERT Operations

CERT personnel assigned to Operations should always be assigned to teams consisting of at least three to four persons:

- One person will serve as runner and communicate with the Command Post.
- Two people will “buddy up” to respond to the immediate needs.
- Search and Rescue Teams must include at least four people with a safety person remaining outside the area to be searched and at least two people to conduct the search.

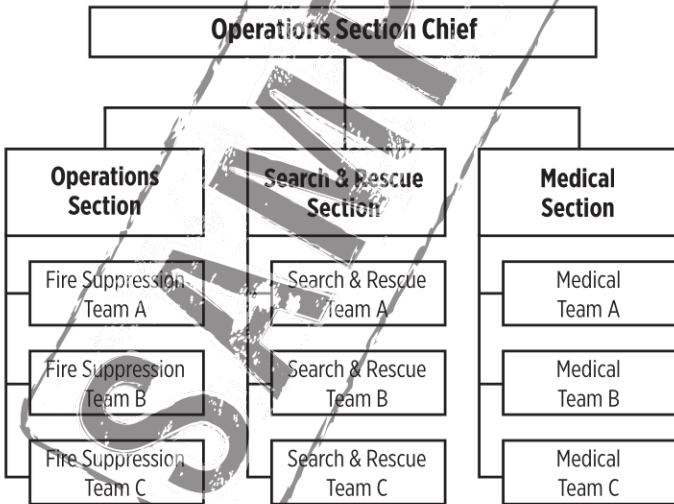

CERT Mobilization

The following steps describe how CERTs mobilize when an incident occurs. Immediately following the incident, CERT members take care of themselves, their families, their homes and their neighbors:

- If the standard operating procedure (SOP) calls for self-activation, CERT members proceed to the predesignated staging area with their disaster supplies. Along the way, they make damage assessments that would be helpful for the CERT IC/TL's decision-making.
- The first CERT member at the staging area becomes the initial IC/TL for the response. As other CERT members arrive, the CERT IC/TL may pass leadership to someone else. The CERT IC/TL establishes operations to ensure effective communication, to maintain span of control, to maintain accountability and to do the greatest good for the greatest number without placing CERT members in harm's way.
- The CERT IC/TL will immediately notify higher authority of CERT Operational Preparedness and availability to conduct operations in their assigned area, including communications methods, with updated command and manpower availability.
- One of the CERT IC/TL's first decisions will be to locate the team's Command Post. The staging area may become the Command Post; however, if another location would be safer or otherwise better the Command Post should be set up there.
- As intelligence is collected and assessed, the IC/TL must prioritize actions and work with the Section Chiefs or leaders. The CERT organization is flexible and evolves based on new information.

Following an incident, information - and therefore priorities - may be changing rapidly. Communication between the CERT IC/TL and response teams ensures that CERTs do not overextend their resources or supplies. Communication must be operational between CERT Command Post and Higher Authority at all times.

Rescuer Safety

Effective emergency scene management requires the formulation and communication of strategic goals and tactical objectives to do the most good for the greatest number while maintaining the safety of rescue personnel.

CERT Rescue Efforts Based on Degree of Damage	
Degree of Damage	Should Rescue Be Attempted?
Heavy	No. Too dangerous to enter. Warn people to stay away. Inform the CERT IC/TL immediately if it is known that people are in the building.
Moderate	Yes, but perform only quick and safe removals; limit on-site medical care to checking for breathing, stopping major bleeding and treating for shock. Minimize the number of rescuers inside the building.
Light	Yes. Locate, triage, continue size-up and document.

Determining a Damage Site

Light Damage Site			
Fire	Search & Rescue	Medical (on-site)	Medical (off-site)
<ul style="list-style-type: none"> • Shut off utilities as needed • Extinguish small fires • Document 	<ul style="list-style-type: none"> • Locate • Triage • Treat airway • Major bleeding • Evaluate • Warn others • Continue size-up • Document 	<ul style="list-style-type: none"> • Triage again • Move to treatment area (nearby safe location) • Head-to-toe assessment • Treatment • Facilitate transport as needed • Document 	<ul style="list-style-type: none"> • Triage again • Head-to-toe assessment • Treatment • Facilitate transport as needed • Document
Moderate Damage Site			
Fire	Search & Rescue	Medical (on-site)	Medical (off-site)
<ul style="list-style-type: none"> • Shut off utilities as needed • Extinguish small fires • Document 	<ul style="list-style-type: none"> • Locate • Triage • Treat airway/ major bleeding • Evaluate • Warn others • Continue size-up • Document 	<ul style="list-style-type: none"> • Triage again • Move to treatment area (nearby safe location) • Head-to-toe assessment • Treatment • Facilitate transport as needed • Document 	<ul style="list-style-type: none"> • Triage again • Head-to-toe assessment • Treatment • Facilitate transport as needed • Document
Heavy Damage Site			
Fire	Search & Rescue	Medical (on-site)	Medical (off-site)
<ul style="list-style-type: none"> • Shut off utilities if safe • Document 	<ul style="list-style-type: none"> • Mark area for heavy damage • Warn others • Gather information • Inform CERT/IC/TL immediately • Document 		

Forms Used For Response Documentation

All forms are located in the *Rite in the Rain* CERT Forms Book (No. 571)

Form	Purpose
Damage Assessment [CERT Form #1]	Completed by CERT members as they travel through the area to the CERT's staging location, then given to the CERT IC/TL; provides a summary of overall hazards in selected areas including: <ul style="list-style-type: none"> • Fires • Utility hazards • Structural damage • Injuries and casualties • Available access • Essential for prioritizing and formulating action plans
Personnel Resources Sign-In [CERT Form #2]	Used to sign in CERT members as they arrive at the staging location; provides information about: <ul style="list-style-type: none"> • Who is on site • When did they arrive • When were they assigned • What are their special skills • Used by staging area personnel to track personnel availability
Incident/Assignment Tracking Log [CERT Form #3]	Used by the Command Post for keeping abreast of situation status; contains essential information for tracking the overall situation.
Briefing Assignment [CERT Form #4]	Used by the Command Post to provide instructions to functional teams; used by teams to log their actions and report new damage assessment.
Victim Treatment Area Record [CERT Form #5]	Completed by medical treatment area personnel to record victims, enter the treatment area, their condition and their status.
Communications Log [CERT Form #6 (ICS 309)]	Completed by the radio operator, used to log incoming and outgoing transmissions.
Equipment Inventory [CERT Form #7 (ICS 303)]	Used to check out or check in CERT-managed equipment.
General Message [CERT Form #8 (ICS 213)]	Used for sending messages between command levels and groups; messages should be clear and concise and should focus on such key issues as: <ul style="list-style-type: none"> • Assignment completion • Additional resources required • Special information • Status update

Disaster Psychology

Team Well-Being

During a disaster, you may see and hear things that will be extremely unpleasant. Be alert to signs of disaster trauma in yourself, other CERT Team members as well as in disaster victims, so that you can take steps to alleviate stress. There are steps that CERT team leaders can take to promote team well-being before, during, and after an incident:

- Brief CERT personnel before the effort begins on what they can expect to see and what they can expect in terms of emotional response in the survivors and themselves.
- Emphasize that the CERT is a team. Sharing the workload and emotional load can help defuse pent-up emotions.
- Encourage rescuers to rest and regroup so that they can avoid becoming overtired.
- Direct rescuers to take breaks away from the incident area, to get relief from the stressors of the effort at least every two hours, depending on assignments and exposure to weather, casualties and other conditions.
- Encourage rescuers to eat properly and maintain fluid intake throughout the operation. Explain that they should drink water or other electrolyte-replacing fluids and avoid drinks with caffeine or refined sugar. When possible, establish scheduled food, drink and rest breaks.
- Conduct a brief discussion (defusing) with rescue workers after their shift during which they can describe what they encountered and express their feelings about it.
- Rotate teams for breaks or new duties (i.e., from high-stress to low stress jobs). Encourage team members to talk with each other about their experiences. This is very important for psychological health.
- Phase out workers gradually. Gradually phase them from high to low stress areas of the incident. For example, do not stand down and send home a team member that has just completed a high-stress operation; instead, assign them a low-stress responsibility so they can decompress gradually.
- Arrange for a debriefing 1 to 3 days after the event in which workers describe what they encountered and express their feelings about it in a more in depth way.

Disaster Psychology

Working with Survivors' Trauma

Traumatic stress may affect:

- Cognitive functioning. Those who have suffered traumatic stress may act irrationally, have difficulty making decisions, or may act in ways that are out of character for them normally. They may have difficulty sharing or retrieving memories.
- Physical health. Traumatic stress can cause a range of physical symptoms from exhaustion to health problems.
- Interpersonal relationships. Those who survive traumatic stress may undergo temporary or long-term personality changes that make interpersonal relationships difficult.

The strength and type of personal reaction to trauma vary depending on:

- The person's prior experience with the same or a similar event.
- The intensity of the disruption in the survivor's life.
- The meaning of the event to the individual.
- The emotional well being of the individual.
- The length of time between the event's occurrence and the present. The reality of the event takes time to "sink in."

Stabilizing Victims:

CERT Member can't know — and should never assume to know — what someone is thinking or feeling. Keep the phases in mind. The goal of on-scene psychological intervention on the part of CERT members should be to stabilize the incident scene by stabilizing individuals. While any medical needs must be addressed first, you can provide psychological intervention in the following ways:

- Observe individuals to determine their level of responsiveness and whether they pose a danger to themselves or to others. Report this observation to the appropriate person, hopefully a medical or counseling professional.
- Get uninjured people involved in helping. Engaging survivors in focused activity helps them cope, so give them constructive jobs to do such as organizing supplies. This strategy is especially effective for survivors who are being disruptive.
- Help survivors connect to natural support systems, such as family, friends or clergy.

Provide support by:

- Listening to them talk about their feelings and their physical needs. Victims often need to talk about what they've been through — and they want someone to listen to them.
- Empathizing. Caring responses show victims that someone is listening. Survivors that show evidence of being suicidal, psychotic, or unable to care for themselves should be referred to mental health professionals for support as soon as possible.

CERT and Terrorism

CERT members should treat possible terrorist incidents the same as they would HAZMAT incidents—**AS A STOP SIGN!** Don't touch it, move away from the object or area, and report it to authorities immediately! Cellular phones and two-way radios create static electricity and may detonate explosive devices. CERT members should always report suspected explosive devices via land line or may trigger an explosive device by transmitting on the same radio frequency.

CBRNE (C-Burn), are five categories of possible terrorist weapons:

- Chemical
- Biological
- Radiological
- Nuclear
- High Explosives

Basic decontamination procedures:

- Leave the contaminated area immediately (at least 1,000 to 1,500 feet upwind and uphill) to limit the time of exposure and reduce contamination levels.
- Take decontamination action. Seconds count! The goal is to limit the time that the agent is in contact with the skin.
- Remove everything from the body, including jewelry. Cut off clothing that would normally be removed over the head to reduce the probability of inhaling the agent and seal clothes in a plastic bag.
- Wash hands before using them to shower. If no shower is available, improvise with water from faucets or bottled water.
- Flush the entire body, including the eyes, underarms, and groin area, with copious amounts of cool water. Hot water opens pores of the skin and can promote absorption of the contaminant. Using large amounts of water is important since some chemicals react to small amounts of water.
 - If soap is immediately available, mix the soap with water for decontamination. Avoid scrubbing with soap because scrubbing can rub the chemical into the skin rather than remove it.
 - Wash hair with soap or shampoo or rinse with water if soap is not available. Do not use conditioner as that can bind radioactive materials to your hair and make it difficult to remove.
 - If hosing someone else off or pouring water from a container, avoid physical contact with both the person and the runoff.
 - The water used for decontamination must be collected and contained outside of the decontamination shelter to avoid shelter contamination. All decontamination water runoff must be handled as contaminated waste.
- Blot dry using an absorbent cloth. Do not rub the skin! Put on clean clothes.
- As soon as possible, emergency responders will set up mass decontamination facilities. For radiological events, stations for radiation monitoring and blood tests will also be set up to determine levels of exposure and what next steps to take to protect health.
- Food Safety. Radioactive particles in food or water may be harmful if consumed. Food in tightly covered containers (cans, bottles, plastic, and boxes) will be safe to eat or drink if you dust or wipe off the containers. Be sure to wash fruit and vegetables and peel them carefully. Water will be safe if it is in covered containers or if it has come from covered wells or from undamaged and uncontaminated water systems.

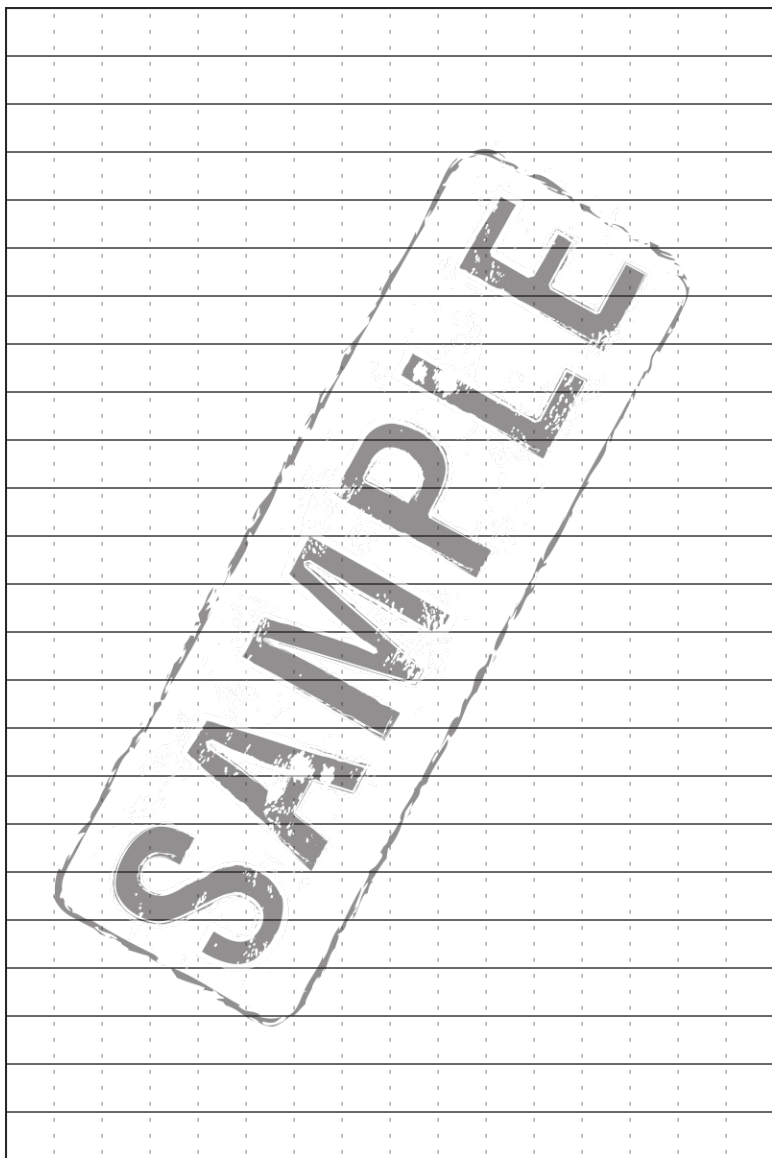

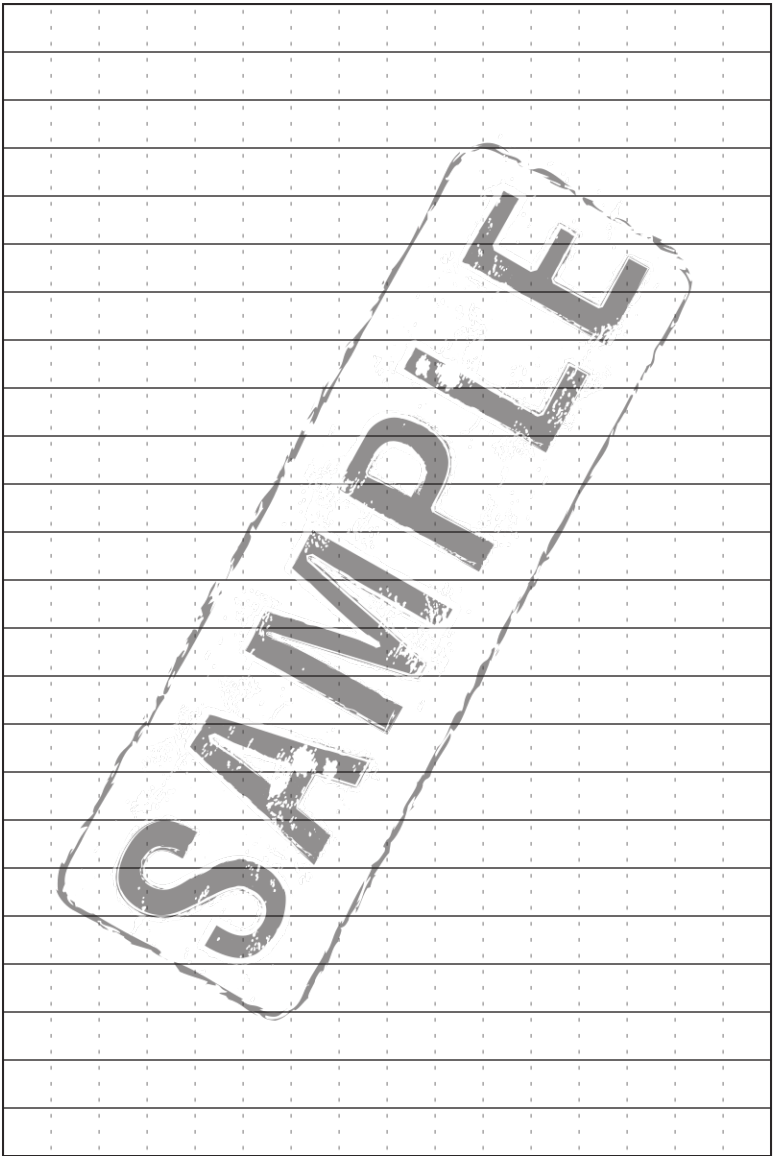

Scale: 1 square = _____

SAMPLE

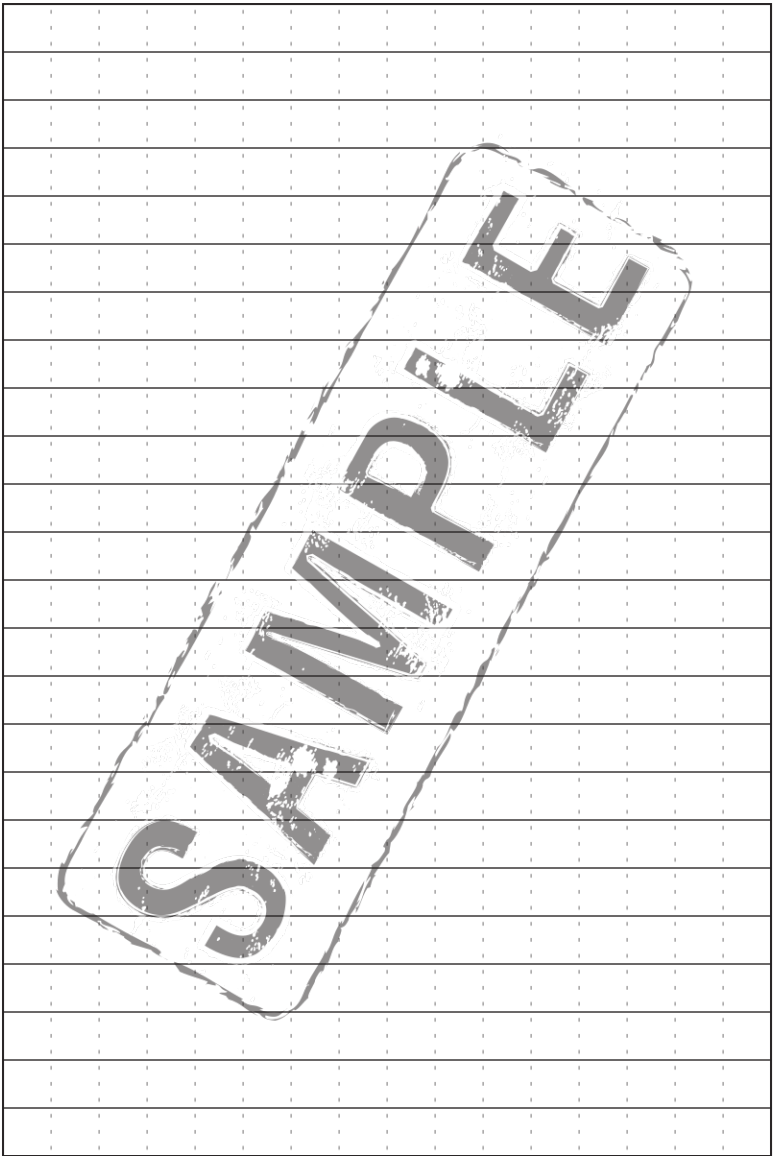

Scale: 1 square = _____

SAMPLE



Scale: 1 square = _____

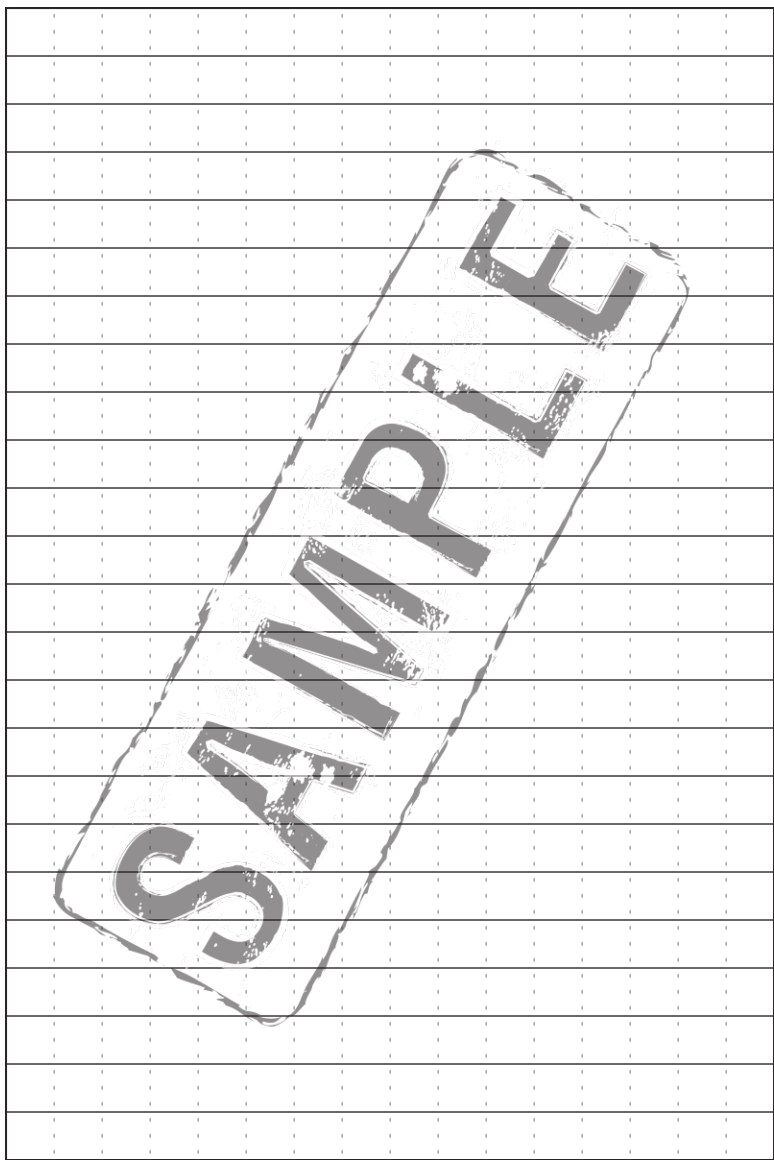

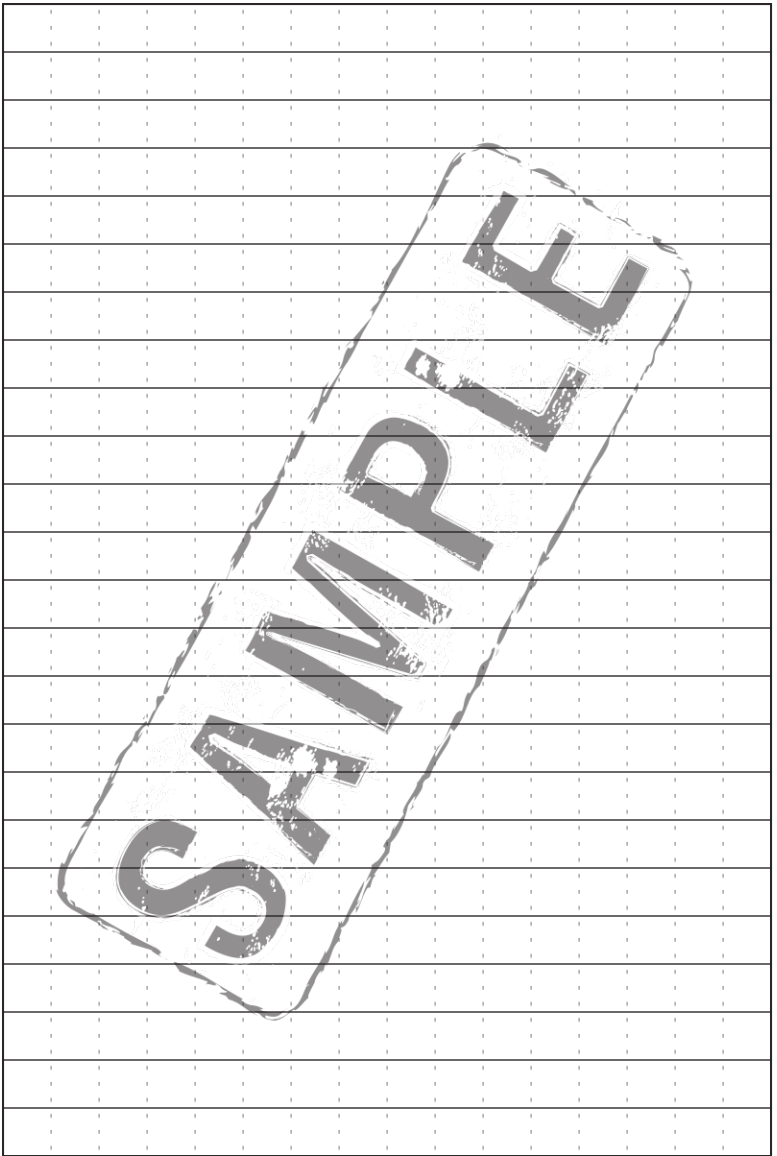

Scale: 1 square = _____

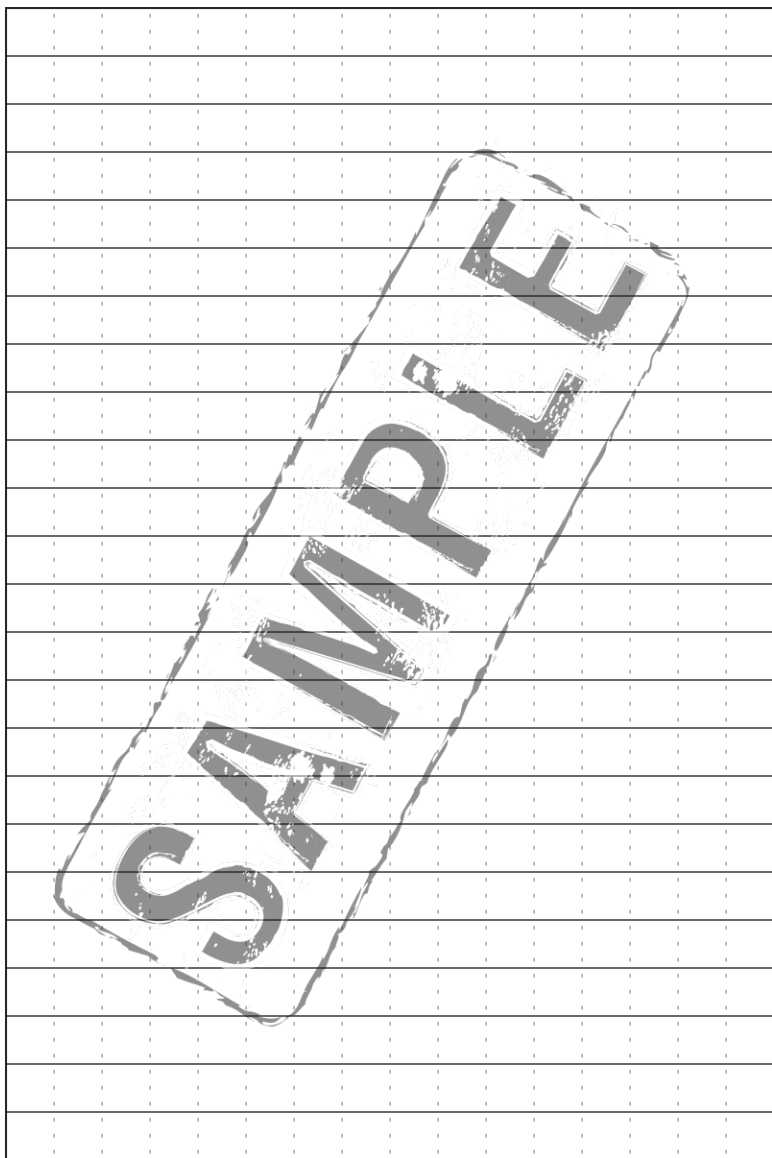

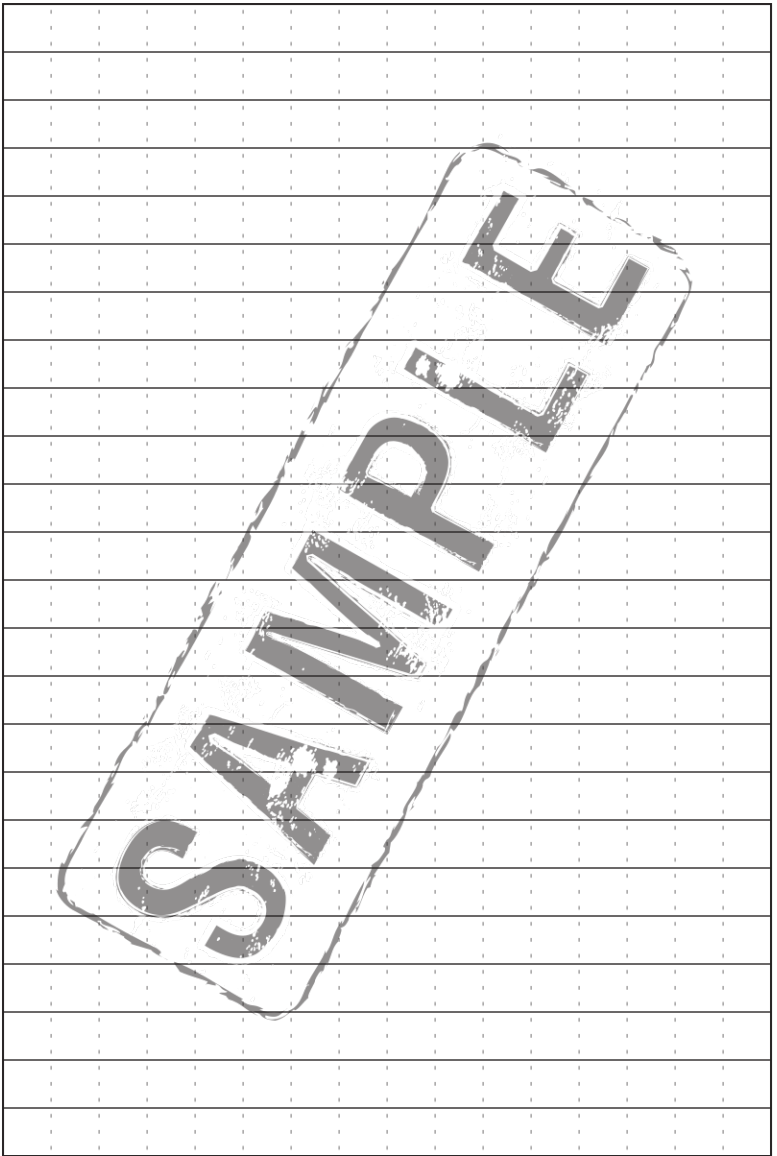

Scale: 1 square = _____

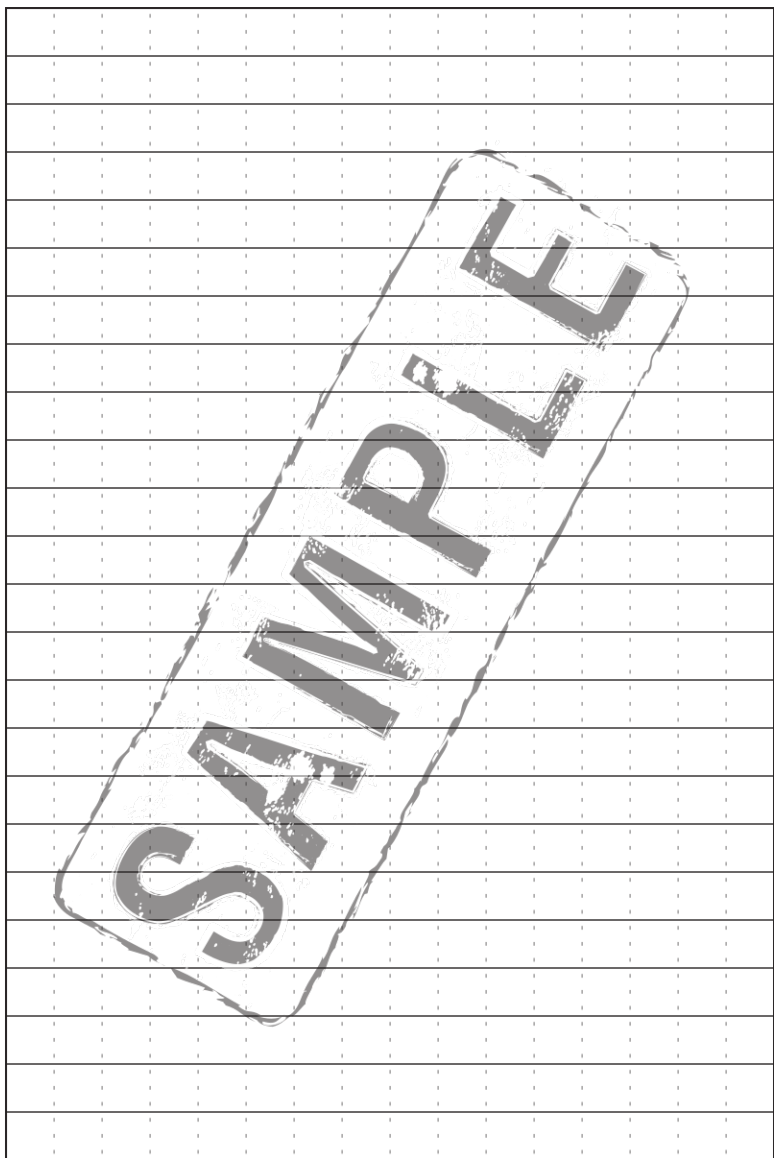

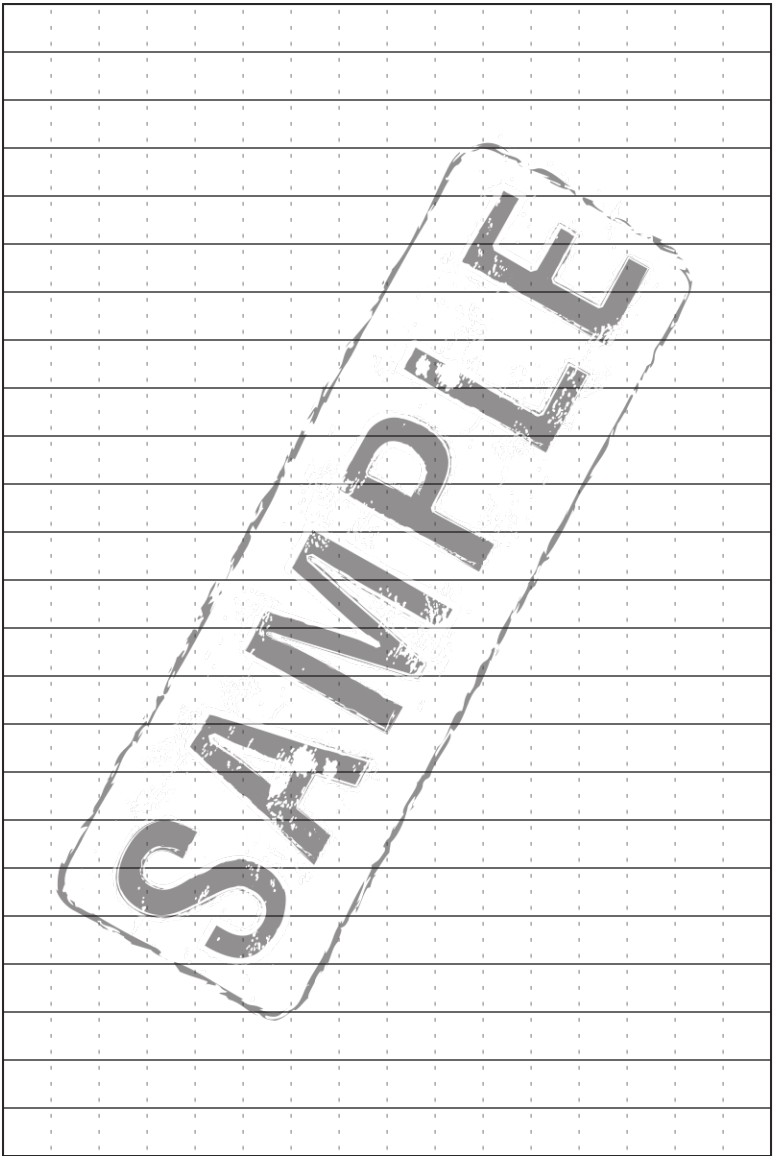

Scale: 1 square = _____

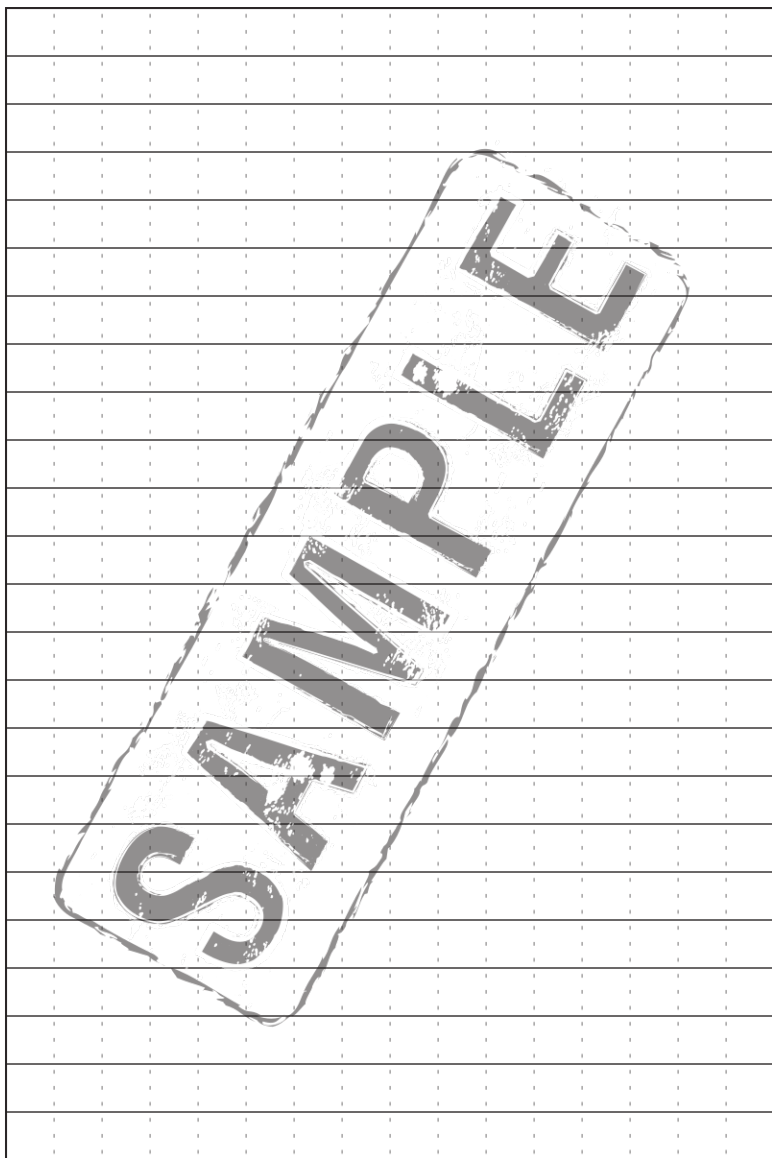

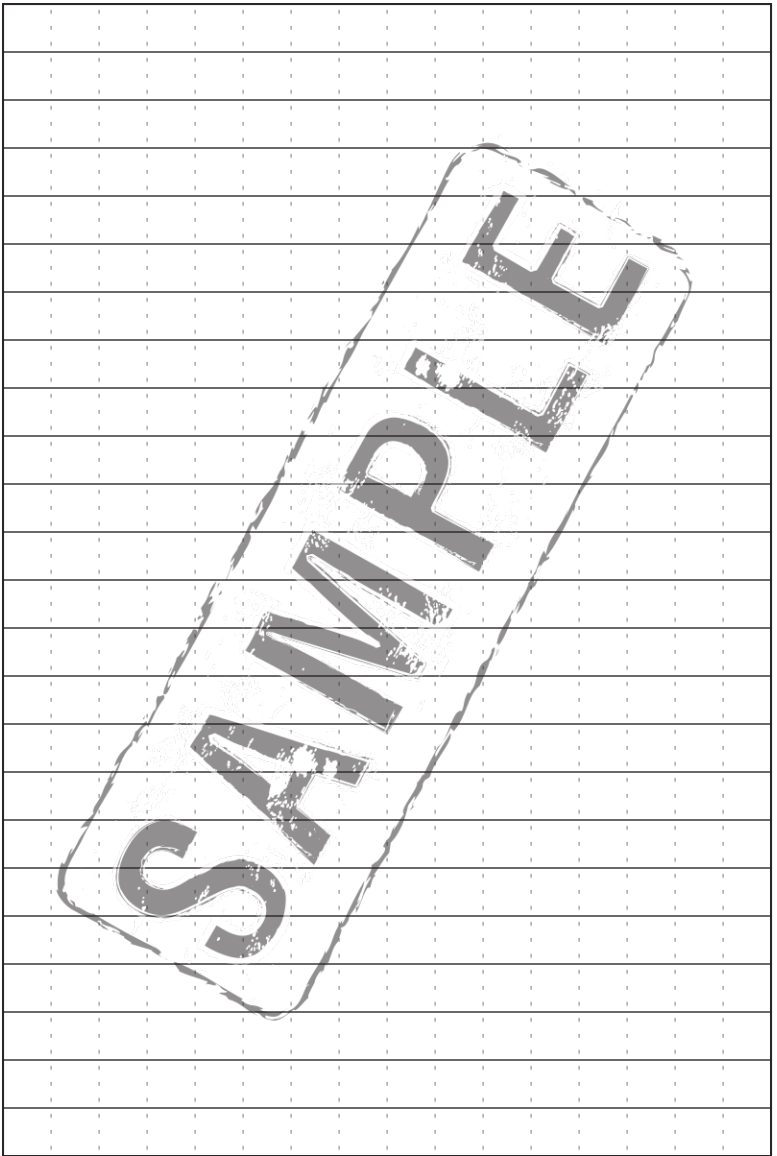

Scale: 1 square = _____

SAMPLE

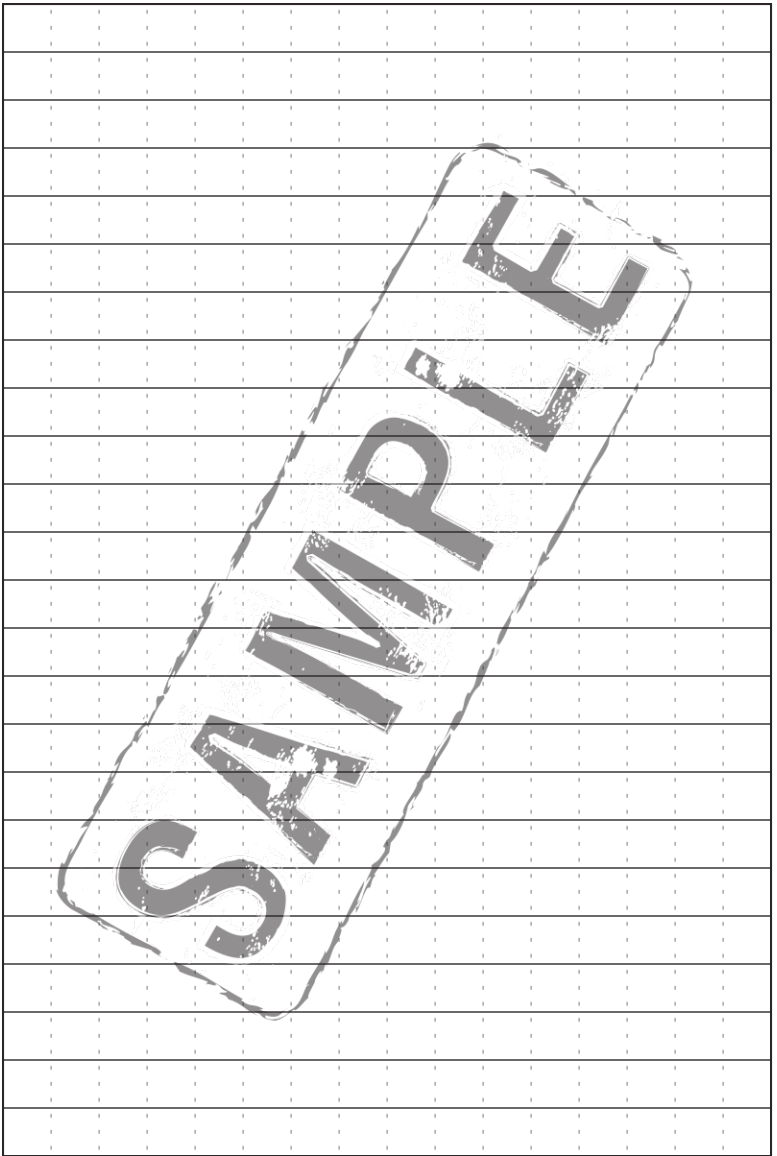

SAMPLE

**Outdoor writing products[®]
for Outdoor writing people**

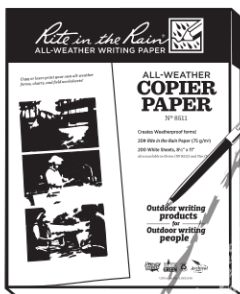

**Copier Paper &
All-Weather Pens**

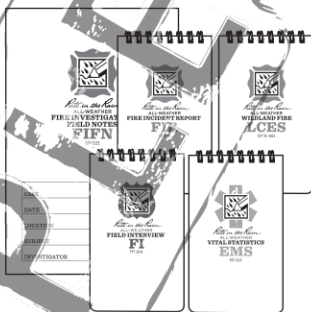

Public Safety Notebooks

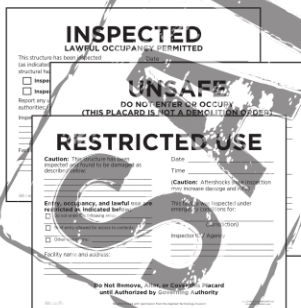

Safety Assessment Placards



**CERT Notebooks / Kit
CORDURA[®] fabric Cover**