

# DEFENSIVE USE OF FIREARMS



# DEFENSIVE USE OF FIREARMS

**Revised and Updated**



**STEPHEN P. WENGER**

Foreword by Bert DuVernay

---

*Defensive Use of Firearms*  
*Revised and Updated*  
by Stephen P. Wenger

Copyright © 2010 by Defensive Use of Firearms, LLC

# Contents

---

Chapter 1: Safety with Firearms	1
Chapter 2: Mental Awareness	7
Chapter 3: Mental Preparedness	11
Chapter 4: Tactics	17
Close Encounters	18
Where to Aim?	20
How Many Shots?	22
Cover and Concealment	23
Low Light	30
Reflections—Friend or Foe?	32
Be Ready to Improvise	33
Chapter 5: Skills	35
Trigger Control	35
Shooting Positions	37
Shooting While Moving	47
Long-Gun Shooting Positions	48
Eye Dominance	50
Aiming the Gun	51
Drawing the Concealed Handgun	54
The Point-Shooting Continuum	58
The Safety Circle	62

## DEFENSIVE USE OF FIREARMS

Carrying the Long Gun	64
Chapter 6: Equipment	67
Handgun Selection	68
Personalizing the Grips	70
Autoloader Choices	72
Ammunition Selection	74
Holster Selection	75
Spare Ammunition	79
Night Sights and Lasers	80
Flashlights	81
Other Equipment	82
Long Gun Selection	83
Chapter 7: Legal Issues	87
Glossary	91

# Warning

---

Firearms are classified as deadly weapons in virtually all jurisdictions. Their use is inherently hazardous. This book is not intended as a substitute for professional training in their use. It is intended as a guide for the selection of that training. Neither the author nor the publisher assumes responsibility for the use or misuse of information contained in this book. Therefore, the information in this book *is presented for academic study only* and should be approached with great caution.



# Acknowledgments

---

- Massad Ayoob: In allowing me to donate my services to his teaching program in Southern California for several years, Mas afforded me the opportunity to make my own separation of the wheat from the chaff in his teachings and writings.
- Peter Samish: Pete welcomed me as a colleague at his Defensive Combat Academy, giving me the opportunity to influence curriculum. Pete not only helped me become a better instructor, he helped me become a better person.
- Louis Awerbuck: Louis' book *Hit or Myth* helped me realize the fallacy of the claim of many instructors that they will fully train you if you merely take more of their courses.
- Bert DuVernay: Bert taught me that if you can't do it safely on the range, you won't be able to do it safely on the street. Bert is one of the great instructors, in part because he values common sense over doctrine.

## DEFENSIVE USE OF FIREARMS

- Peter Burlingame: Pete showed me that since tactics are more important than shooting skills, they can and must be incorporated at the earliest levels of defensive firearms training.
- Richard Grassi: Rich proved to me that you need to spend most of your range time with the guns you actually carry, not the ones that are the easiest or most fun to shoot.
- Clive Shepherd: Clive taught me a great many techniques and tactics, as well as how to teach them to others and how to conduct relevant training on a low budget.
- Jim Cirillo: Jim made innumerable contributions to the “software” side of the discipline and was kind enough to share many of his experiences with me.
- Jim Andrews: As he did with everyone he considered a friend, Jim taught me countless things about both the hardware and the software sides of fighting in order to stay alive and intact.
- Rex Applegate: Colonel Applegate attempted to take me under his wing, forcing me to rethink all I had been taught previously about point shooting. He generously supplied me with books, videos, and contacts.
- Andy Stanford: I turned to Andy to learn how to translate low-light shooting techniques into low-light tactics. In the process, I was forced to rethink some of my earlier tactical concepts.
- Robert Chu: Robert not only shared his interpretation of the art of wing chun kuen, he also shared his students.

## ACKNOWLEDGMENTS

This finally afforded me the opportunity, in my late 40s, to develop the ability to visually analyze human movement.

- Harold Flynt: Harold has always supported and encouraged me, even in my most doctrinaire times. He has always been a source and a sounding board for tactical issues.
- Ralph Mroz: Ralph is a fellow “analyst” who has helped crystallize my view that training only with a firearm is insufficient for anyone who’s serious about self-defense.
- My students: Those who trust me to help them prepare for life’s worst moments have been and shall remain my greatest teachers.



# Foreword

---

Of the thousands of instructors and students I've worked with, Steve Wenger is one of the most meticulous, clear-thinking, and dedicated students of self-defense I've ever encountered. This book is representative of that experience. It is a good place to start for the beginner and a challenging review for the experienced defensive shooter, as well.

Steve's approach is simple and straightforward, as are most of the answers to the questions surrounding the issue of defending oneself, with a firearm or otherwise. Unfortunately, all too many instructors and authors tend to unnecessarily complicate defense and gunhandling issues. While some of the techniques advocated by some might help the reader excel in the competition arena, they would prove to be lacking in a fight. This book avoids those pitfalls.

The chapter on tactics is a good example of the difference between fighting and competing. The tactics described are as street proven as they are simple, but would not be advantageous in the sterile, safe setting of the competition field. Likewise, the chapters on safety and legal issues are deceptively short. While short on verbiage and complicated notions, they are long on distilled knowledge and wisdom.

Steve has a knack for cutting through the smoke and getting to

## DEFENSIVE USE OF FIREARMS

the point on an issue. I can think of no subject that benefits more from that talent than the defensive use of firearms. Pay close attention to his message, and you will be well served by this book.

Bert DuVernay  
Chief of Police, New Braintree, Massachusetts  
Former Director, Smith & Wesson Academy

# Preface to the Updated Edition

---

When the original edition of this book was released, in March 2005, I warned in the preface:

*I don't envision my effort as some sort of bible. I still regard myself as a student or scholar of the discipline. I am setting forth what seems reasonable at this time—I may learn better in the future. I am not attempting to write an encyclopedia—there are many other useful books out there that won't be rendered obsolete by my efforts.*

Within a few months, I had the opportunity to take some live-fire training in point shooting with Matt Temkin at the 2005 Annual Training Conference of the International Association of Law Enforcement Firearms Instructors. In this course, Matt emphasized what W.E. Fairbairn and E.A. Sykes called the three-quarter hip position. As a result of this training, I reexamined the teaching of this pair, via their book *Shooting to Live with the One-Hand Gun*. Among my conclusions, I realized that the protected-gun position I had been teaching for use at arm's length was actually an enhanced version of their quarter-hip or close-hip position. Since that time I have incorporated their continuum of quarter-hip, half-hip, and three-quarter-hip positions into my teach-

## DEFENSIVE USE OF FIREARMS

ing curriculum and have come to view most of the sighted-fire techniques I teach as extensions of that same continuum.

Paladin Press agreed to give me the opportunity to update this book, to include these crucial skills. I have also corrected and updated a few things that either reflect insights I have gained teaching in the years since early 2005 or new developments in the field of which I have become aware.

If this is your first reading of either edition of this book, please take a moment to read the earlier preface as well.

Show Low, Arizona  
July 2010

# Preface

---

*There is nothing new under the sun.*  
—Ecclesiastes 1:9

---

Then why read this book? I am not a gunfight survivor; so far I have only had to draw a gun once on a hostile adversary. I am an above-average shooter but would not expect to take home any trophies if I chose to get involved in competition. I have never worn a badge, although I have donated thousands of hours of volunteer time to one of the nation's largest law enforcement agencies. I have been fortunate to have had access to a great deal of law enforcement training, and I hold a few instructor certifications through the National Rifle Association's Law Enforcement Activities Division.

I have, in the words of one of my long-ago professors, "a questioning mind, a trait that may not be desirable in many occupations but one that is highly desirable in a scholar." This questioning mind has caused a fair deal of distress for several of my professors, as well as a few of my firearm instructors. Those in the second group who have been distressed have usually objected to my spoken or unspoken question: "Is this going to do me any good once I get off your range?"

My primary interest in firearms has always been self-defense. A few years ago I posted a website, ~spwenger's Defensive Use of Firearms (now located at [www.spw-duf.info](http://www.spw-duf.info)), largely in response to my disillusionment with most of what I had been reading for years in gun magazines and some of what I had been taught or had seen being

## DEFENSIVE USE OF FIREARMS

taught on the range. Many people who visited the site asked why I didn't write a book. In spring 2001, I decided it was time to do so, consolidating some of what I had posted on the website with some of the additional material that I teach my students. After a few episodes of writer's block, I finished the text in the fall of 2002. The next delay was in producing the illustrations. I was fortunate to have Jeff Cahill, a student, volunteer for that assignment in early 2003. Jeff's commitment to provide enhancements for some of the firearms used by our military personnel in recent conflicts delayed this project, but I believe that the illustrations were worth the wait.

I don't envision my effort as some sort of bible. I still regard myself as a student or scholar of the discipline. I am setting forth what seems reasonable at this time—I may learn better in the future. I am not attempting to write an encyclopedia; there are many other useful books out there that won't be rendered obsolete by my efforts.

The strength of a firearm is that it can concentrate a lot of energy in the form of one or more projectiles launched in relatively straight lines. The weakness of a firearm is that it can launch its projectiles only in relatively straight lines. Further, the lawful use of a firearm in self-defense is restricted to a very narrow set of circumstances. Thus, the role of the firearm in self-defense is only a narrow band in a much wider spectrum.

Massad Ayoob taught me that there are four priorities for survival: mental awareness and preparedness, tactics, skill, and, lastly, choice of equipment. The gun magazines are full of articles on equipment; they are the easiest articles to write, and they usually curry favor with advertisers. It is more challenging to write meaningful material about the higher priorities.

I have come to disagree with Ayoob about the priorities. I consider mental awareness and mental preparedness to be separate issues. Most of us know at least one person who says, "I could never bring myself to harm another human being. I would have to let him kill me." Even such people can avoid most threats simply by being aware of their environment and what's happening in it. The mental

## PREFACE

preparedness to fight back, with whatever means are available and necessary, is a separate issue and one that has not always been confronted by those who may have made physical preparations to defend themselves.

Therefore I rank the priorities to survive and to prevail as follows:

1. Mental awareness
2. Mental preparedness
3. Tactics
4. Skill
5. Choice of equipment

Along with an opening chapter on safety and a closing one on legal issues, these priorities form the basic outline of this book. These priorities or principles are interrelated. For example, your choice of tactics may be conditioned by your level of skill and your choice of equipment.

This book presents what I think are common-sense views about these principles and related training. It is oriented primarily toward the gun owner who has realized that simply owning a firearm doesn't confer protection and that not everything labeled "tactical" involves good tactics. I believe it will be useful to the person who may not yet own a firearm but is contemplating the value of doing so. I hope that it will also be of value to those who have already sought professional training in this field and may be ready to assess the value of the training that they have received.

If you don't already know everything about this subject, this book may answer some of your questions. If you do, I hope that it will ask you some new ones.

Show Low, Arizona  
March 2005



# 1 Safety with Firearms

---

*They that can give up essential liberty to obtain a little temporary safety deserve neither liberty nor safety.*  
—Benjamin Franklin, *Historical Review of Pennsylvania*

---

This book is intended for people who have the liberty to look to firearms as a means to enhance their personal safety and, perhaps, the safety of those they are obliged or sworn to protect. Firearms are deadly weapons and, if misused, have a great potential to lessen the safety of those around them. Most defensive firearms instructors teach four basic safety rules, even though the wording may vary slightly:

- *Rule 1: All firearms are always loaded.* Some people teach this as “all firearms are presumed to be loaded.” The point is that the majority of people who have been shot unintentionally have been shot with firearms that were presumed to be unloaded. Even when dry-firing with firearms that have been verified as unloaded, the user must aim the gun at a backstop that will stop the most damaging projectile out of the bore the first time the user fouls up.
- *Rule 2: Don't let the muzzle cross anything you're not prepared to shoot.* Should a massive discharge of static electricity mysteriously ignite the cartridge in your firearm, no one should be seriously injured if the firearm is not pointed at anyone. An older

## DEFENSIVE USE OF FIREARMS

version of this rule advises “Always point the muzzle in a safe direction.” There is no absolutely safe direction, and if someone poses an immediate threat to your life, you will likely need the firearm pointed at the assailant to terminate the threat.

- *Rule 3: Keep your finger out of the trigger guard (up on the frame of the gun) until your sights are on the target and you’re prepared to fire.* Without that mysterious massive discharge of static electricity, it is very difficult to conceive of how a firearm in your hand will fire if your finger or some other object doesn’t come in contact with the trigger. This is the hardest rule for people to follow for a couple of reasons: firearms are designed to be held with the finger on the trigger, and virtually everyone who has grown up in modern society has been bombarded with photos, movies, and TV programs where models and actors are routinely pictured with their fingers on the triggers.

An older version of this rule says “Keep the finger off the trigger . . .” This is a common practice among target shooters, simply breaking contact with the trigger but leaving the finger inside the trigger guard. If the shooter is bumped or startled or trips while moving, the gun is likely to get fired unintentionally. Likewise, if the finger is merely placed on the front of the trigger guard, the reaction of clenching the fist when startled can also result in an unintended discharge as the finger snaps off the trigger guard toward the waiting trigger. Further, videotapes of people in training scenarios with unknown situations show that shooters tend to let their fingers drift back to the trigger unconsciously. Keeping the finger on a higher plane than the trigger until you are prepared to fire is a very important supplement to merely keeping it out of the trigger guard.

- *Rule 4: Always be sure of your target and what’s beyond it.* There is absolutely no excuse for shooting at an unidentified target. The reason for also being sure of what’s beyond your intended target

## SAFETY WITH FIREARMS

is that the bullet may penetrate the target and strike whatever else is in line with it downrange. When shooting at paper or cardboard targets, you are virtually guaranteed that the bullet will penetrate the target. Hunters frequently select their ammunition intentionally to penetrate the game that they shoot and make a better blood trail if the animal doesn't go down right away. In training and sporting environments, you have no excuse for not being sure of what's beyond the target. In a defensive shooting, it is possible that you may be so focused on the threat that you may not even see what's beyond it. This is a good reason to select ammunition that is not likely to exit a human target.

Rules two and three, in particular, function together to give a 100 percent safety redundancy. If you do inadvertently cross innocent parties with the muzzle, you can't shoot them if your finger is out of the trigger guard. If the finger drifts into the trigger guard unintentionally, but the gun is pointed at something like a brick wall, the inadvertent discharge will cause minimum damage, absent a serious ricochet.

There is a supplementary gunhandling rule known as the condition check. Largely an extension of rule one, it states: Whenever a firearm has been out of your control, even if only for an instant, check the condition of the chamber(s) to make sure that the firearm is in the condition in which you want it, loaded or unloaded. A "click" when you expect a "bang!" can be as deadly as a "bang!" when you expect a "click."

At the urging of attorneys Michael Anthony and Robert Brown, I now teach a fifth safety rule. This rule derives from their finding that most successful lawsuits against gun owners involve misuse of the guns by people other than their owners.

- *Rule 5: Maintain control of your firearm.* Some states provide criminal penalties for people whose firearms are misused because of improper storage. In virtually any U.S. jurisdiction, a

## DEFENSIVE USE OF FIREARMS

gun owner who fails to take reasonable precautions to restrict access to his firearms will likely be held accountable in civil court for damage caused with them. Firearms carried in public are best carried on one's person in a holster. Handguns tucked into waistbands can slip loose. Handguns carried in bags, briefcases, purses, and the like may be set down and stolen or forgotten. Firearms stored in the home are best kept under lock and key, not hidden under couch cushions or other places where they may be found by children, burglars, or visitors who may not be trained in their safe use.

There is a caveat to Rule Five. If a firearm is dropped, let it go to the ground. Most modern firearms will not discharge when dropped, but there is definitely a risk of firing a dropped gun, particularly a handgun, if it is caught with a finger or thumb inside the trigger guard. Personally, I know of one case of a police officer who shot herself in the head in this manner; miraculously, she survived.

Dry-firing is an essential exercise to develop and maintain good trigger control. It is, however, a violation of Rule One. Firearms should be checked several times, by sight and feel, to ensure that they are truly unloaded. Ammunition should be left in another room or otherwise secured during any dry-firing. As mentioned above, dry-firing must always be done with the firearm aimed at something that will stop anything that exits its muzzle. People who own ballistic vests are well advised to use them as dry-fire targets—they are less likely than a hard surface to produce ricochets.

Reloading practice should be done with a disabled handgun. The slide assembly can be removed fairly easily from most pistols, and a strip of cloth can be tied around the top strap of most revolvers, preventing the cylinder from closing. Arguably, reloading practice could be done with dummy rounds, but they have been known to exchange places with live rounds. Remember, a “click” when you expect a “bang!” can be as deadly as a “bang!” when you expect a “click.” If you want to practice reloads with a long gun that can't be disabled,

## SAFETY WITH FIREARMS

do it at a range and keep the muzzle aimed at the backstop. Do not practice dry-firing and reloading in the same time frame. Because anyone who has fired live rounds has had the experience of loading, aiming, and firing, the risk of doing so inadvertently is too high to take in an environment where you don't really want to fire a round.

There are some other safety concerns besides ballistic injuries from firearms.

- *Firearms produce sounds loud enough to damage hearing.* Even .22s have the capacity to damage hearing, and some long guns actually produce enough noise to damage hearing when dry-fired repeatedly because they are usually fired with part of the face pressed to the stock. This brings up the issue of bone conduction. Although earplugs reduce the level of noise traveling through the ear canal, when sounds get loud enough they travel through bone to the inner ear. When there is not a high priority on hearing instructions or range commands, and high-power guns are being fired, it is wisest to use both plugs and muffs. Children are particularly susceptible to hearing damage, not only because the inner ear is more vulnerable while it is maturing but also because it is closer to the surface of the head until the skull reaches its full size.
- *Eye protection is essential anytime guns are being fired.* Although eyeglasses may provide only limited protection against catastrophic failures of firearms, they generally provide protection against more likely hazards, such as unburned powder granules, ejected cases, bullet shavings from revolver forcing cones, and droplets of hot oil that may come off the rear of the slides of autoloading pistols. Eye protection is also essential for those who reload ammunition. Whether or not your first choice in fashion, eyeglasses (even with plain lenses) make a lot of sense for anyone who has the foresight to make preparations for self-defense.

## DEFENSIVE USE OF FIREARMS

- *Until very recently, virtually all ammunition included lead-based primers and bullets.* Manufacturers of ammunition with lead-free primers usually advise using it only for training because its ignition isn't as dependable as that with the lead-based primers. Avoid eating, drinking, and, if you still persist in doing so, smoking while shooting. Wash your hands and the facial area around the mouth between shooting and engaging in those activities. Be cautious about shooting on indoor ranges where you can't feel a constant flow of air on the back of your neck and where you see accumulated lead dust on the floor.

Small amounts of lead are briefly vaporized when conventional ammunition is discharged in a firearm. This vapor quickly condenses to fine particles. If you must shoot in an environment where you feel the need to use a respirator while shooting, you must use one rated for lead mists. While swallowing a large lead bullet probably won't produce a measurable increase in your blood lead level, the particles produced in lead mists and when bullets impact on steel backstops and targets are small enough to dissolve in stomach acid, allowing the lead to get into the blood. Repeated exposure of this sort will eventually produce toxicity, affecting almost all organ systems of the body. Additionally, the lead will get incorporated into bone, allowing the lead to persist longer in the body, even after you take steps to limit exposure. Take all reasonable steps to avoid tracking these tiny particles into your home, where they will find their way into carpeting and upholstery and continue to find their way into your body for years to come. Take similar precautions while cleaning firearms and reloading ammunition. I now use one of the water-based bore cleaners for all but high-power rifles in order to reduce exposure to other potentially toxic chemicals that can be inhaled from the more traditional solvents.

# 2 Mental Awareness

---

*Therefore the skillful leader subdues the enemy's troops  
without any fighting . . .  
Sun Tzu, *The Art of War**

---

Many defensive firearms instructors teach some version of a color code of awareness. In this code, condition white represents a lack of awareness. We are an automobile-oriented society. In an automobile, condition white is represented by the driver who is so engrossed in the song on the radio, the conversation with his passenger, or his plans for the weekend that he is unaware of the threats posed by other vehicles or other potential hazards on the road—or of the threat he poses when he makes lane changes without checking whether his path is clear to do so.

Condition yellow is usually described as some manner of relaxed awareness. Again, using an automotive analogy, a defensive driver is in condition yellow, aware of the movements of other vehicles on the road, balls rolling into the street that may signal a child to follow, the sounds of sirens or horns, or the elderly person about to enter the crosswalk.

Some people may have learned everything they need to know in kindergarten, but I learned something very valuable in my high school defensive driving course: the five keys of the Smith System of defensive driving. About 80 percent of the information that most of us receive comes through our eyes, and four of the five Smith keys are useful to maintain awareness of our environment and what is happening in it:

## DEFENSIVE USE OF FIREARMS

1. *Aim high in steering.* For the driver this means looking more than one block ahead to anticipate potential problems. When you are on foot this means looking up, not at your feet. Not only does this minimize the likelihood of walking into a situation you may not be able to handle, it also communicates nonverbally that you are aware and not a victim of choice.

2. *Keep your eyes moving.* For the driver this means continually sweeping not only the road ahead but also the rear- and side-view mirrors. When you are on foot this means scanning such places as alleys and doorways and such sources of reflection as store windows, and avoiding tunnel vision in general.

3. *Get the big picture.* For the driver this means assembling visual (and auditory) input to anticipate potential hazards. When you are on foot, this means recognizing that such items as ski masks aren't normal attire in warm weather or making sure that someone demanding your attention doesn't distract you from seeing his partner approach from a different angle.

4. *Leave yourself an out.* For the driver this means things such as not getting boxed in between three or four vehicles, leaving no options if the one in front should stop suddenly or one on the side should swerve into your lane. When you are on foot, this means things such as not automatically going for the one restaurant seat with your back against the wall if it denies you an avenue of escape, as well as knowing where you will dodge or duck for cover if you need it.

5. *Make sure they see you.* For the driver this is a precaution to minimize careless action by other drivers. When you are on foot, this may be a liability—you may frequently benefit by getting through potential trouble spots unobserved.

## MENTAL AWARENESS

Mental awareness can be enhanced by playing the “what if” game. What would I do if a robbery is announced while I’m in the checkout line in the supermarket? What would I do if a panhandler pulled a knife on me? What would I do if someone climbed through my bedroom window? What would I do if someone tried to carjack me at a stoplight?

A very important part of mental awareness is learning to listen to our gut feelings. Gut feelings actually have nothing to do with our guts; they have to do with experience and pattern recognition. They are actually a subconscious form of prejudice, in the broader sense of having prejudged, rather than in the narrow, contemporary sense of bias. Prejudice is a form of learning; the challenge is to distinguish whether it is functioning in a positive or a negative manner so that we ensure that it doesn’t work against us. Thus, if we assume that all people of a certain ethnic origin are bad, we may prejudge unfairly and possibly cause harm to another, deny ourselves a valuable friendship, or take inappropriate action that could come back to haunt us. However, if we notice a group of shabbily dressed men clustered near the entrance of a liquor store in our path, we do no harm by choosing a different route to walk and may well avoid trouble. The caveat is that we do no harm if our gut feeling or prejudgment leads us to change our route or take some unseen measure of preparation. If it leads us to draw a gun prematurely, it may land us in jail.

The best way to win a fight is to avoid it. Barring that, the next best thing is to know that it is coming and to make the other guy fight on our terms.



# 3 Mental Preparedness

---

*To every thing there is a season . . . a time to kill,  
and a time to heal.*

Ecclesiastes 3:1–8

---

Because I have never taken any training at the late Jeff Cooper's school, Gunsite, it was relatively late in my training that I learned that what I had been taught as Jeff Cooper's color code of awareness is actually his color code of preparedness. This made tremendous sense when I learned of it, because I had always questioned the significance of condition orange and condition red as conditions of awareness. Also, I had already developed parallel concepts from other sources.

My late friend Jim Andrews, who had been forced to kill men while wearing both military and police uniforms, told me very early in our relationship that it was a very different experience in each environment. When I pressed him on this, he finally explained that in the wartime military your enemy is systematically dehumanized for you in training, to reduce your reluctance to kill him. In a civilian environment, with or without a badge, Jim continued, you will be dealing with a human being when, suddenly, before your very eyes, he becomes a monster that requires you to unleash deadly force.

It is estimated that 98 percent of the population has a great reluctance to kill a member of our own species. In fact, most animals will engage only in ritual combat with members of their own species. Our species is the one with the highest intellect on the planet. On the one

## DEFENSIVE USE OF FIREARMS

hand this intellect has allowed us to develop great civilizations, together with arts and sciences. On the other hand it has, arguably, made us the planet's most efficient and vicious predators. In civilized societies most of us spend the bulk of our time in the first mode. For most of us, the predator side surfaces only when we are forced to fight, although some may feel it when they hunt another species.

The point of the color code of preparedness is to encourage the armed citizen to be aware that the need to employ deadly force may occur and to facilitate the transition to a fighting mode when it does. Thus the person in condition white is in denial of this need or senses a barrier to the use of deadly force. The one in condition yellow is aware of the possibility or has slightly lowered that barrier. The one in condition orange has recognized a potential threat, and the barrier has dropped very low. The one in condition red has identified a specific threat, and the barrier has been removed; the assailant's further behavior will determine whether the defender needs to employ that deadly force.

Mental preparedness, however, need not be limited to those who carry firearms. Those who have made the decision not to submit to physical violence need to be able to fight with whatever means are available. Even those of us who carry guns may spend a portion of our time in environments where we aren't allowed to be armed, such as in a school, a workplace, an airplane, or a jurisdiction that infringes on the natural right of self-defense.

Recently there has been concern in the training community about the ability to perform certain skills while under the influence of the sympathetic branch of the autonomic nervous system (SANS). Some people use the term body alarm reaction for what they view as a major discharge of the SANS. They attribute most of its effects to epinephrine, a hormone released from the center of the adrenal glands in response to signals from the SANS; for this reason epinephrine is also known as adrenaline. There is no question that high levels of stress—or, to use the legalistic term, fear for your life—can hinder life-saving performance. The question is whether it is inevitable.

## MENTAL PREPAREDNESS

From my knowledge of the human nervous system and my limited personal experience, I believe that training, confidence in the skill produced by that training, and a proactive attitude can limit the loss of skill. A psychologist friend agrees emphatically with this, referring to realistic training as inoculation against the loss of both physical and mental skills in the face of physical danger. (Inoculation normally refers to the process of vaccinating people against disease by giving them a weakened version of the infecting agent in order to prepare their immune system to fight the real thing.)

Whether or not you accept the theory of evolution, it is a fact that as our embryos develop, our organs go through stages that very closely resemble those of simpler animals. This is particularly true of our central nervous system. What most distinguishes us as humans is not the opposable thumb that can grasp from the side opposite the fingers; it is our highly developed cerebral cortex, the thinking part of our brain. However, deeper in the brain is an “older” area known as the reptilian brain, the limbic system, or the emotional brain. Part of this limbic system is a pair of almond-shaped structures called amygdalae (plural for amygdala). This is the part of the brain that is responsible for fear, and it has the capacity to “short out” the thinking part of the brain.

The autonomic nervous system is usually divided into the sympathetic and parasympathetic branches. The former prepares the body for fight or flight, and the latter is associated with rest and repair. The term autonomic is used because this portion of the nervous system controls bodily functions without conscious thought. It used to be thought that it couldn't be influenced by conscious thought, but we now understand that such things as meditation and breath control can strongly influence many bodily functions, as can anxiety.

The point is that the autonomic nervous system is an extension of the central nervous system, and the adrenal glands are merely amplifiers of the SANS. The epinephrine, or adrenaline, released by the adrenal glands doesn't even get into the brain. This is because it is a polar substance, meaning it tends to remain in the watery environ-

## DEFENSIVE USE OF FIREARMS

ment of the blood rather than moving to the fatty environment of the brain. Some people argue that epinephrine plays a role in shunting blood to different areas of the brain, but it can't do so until after the brain has had time to activate the SANS, which in turn has to stimulate the adrenals, which have to release the epinephrine, which then has to travel through the bloodstream.

My argument is that when fright or stress interferes with our ability to perform, it is the result of what happens in the brain, not the release of epinephrine. Thus, if we are successful in our inoculation process, we can limit the degradation of our fighting skills.

An additional requirement is a proactive attitude toward dealing with deadly threats. Once we recognize that someone is seriously threatening our physical well-being, we can't afford to remain in a purely reactive mode. If we merely react to the assailant, we remain behind the curve because action beats reaction. This doesn't mean that you must shoot someone because you have drawn your gun. It means you must gain the initiative and force the assailant to react to your moves. If he decides that he has an urgent need to be someplace else, you probably won't need to shoot him. Once you see yourself in the proactive role, you will have taken a major step toward blocking the slide into fear.

I use the term proactive rather than offensive because the dichotomy of proactive versus reactive will be a more useful one than offensive versus defensive in the aftermath of a self-defense incident. "Offensive" won't be viewed favorably in our legal system, which will need to hear "defensive" as a justification for our use of force. For the same reason I can't counsel "don't get scared, get angry." Anger is usually viewed in court as the opposite of reason. Nonetheless, a rose by any other name would still smell as sweet. Consider:

- LAPD officer Stacy Lim was followed home from work in an attempted carjacking. She was shot in the chest with a .357 Magnum round that actually contacted her heart. She killed her attacker before losing consciousness. When I met Stacy about a year later, in

## MENTAL PREPAREDNESS

November 1991, she was back on full duty, albeit after having undergone open-chest heart massage and a couple of defibrillations.

- In the early 1990s, four Bureau of Alcohol, Tobacco, and Firearms agents were involved in a shootout with a South Central Los Angeles gang member. When the shooting was over, the gangbanger had 34 entry wounds and 27 exit wounds from 00 buckshot pellets, 9mm bullets, and 12-gauge shotgun slugs. He was removed from the gene pool only because the last shotgun blast of the engagement destroyed his genitals. Last I heard, he was still alive in a federal prison, albeit getting rid of his urine through a bag worn on his belly.

Both of these people were obviously in exceptional physical condition, but it was their fighting attitude that was the primary element of their survival. You can be sure that these two people on opposite sides of the law didn't wait until they were looking down the barrel of someone else's gun to make the decision to fight back with everything they had.

One more point: legendary Marine Corps sniper Carlos Hathcock spoke of "going into the bubble" every time he took a shot. By this he meant that he shut out the rest of the world just long enough to concentrate on the principles of marksmanship. U.S. police officers average only about 20 percent hits in gunfights, or as my late friend Darrell Mulroy preferred to view it, they miss about 80 percent of the time. Darrell attributed this to training in shooting systems that crumble in the face of fear. Darrell and I disagreed on this point. In the same manner that you should train to develop the physical skills for combat, you have to train to develop the mental skills. One portion of the latter training is to place yourself in the bubble for the brief instances in which you have to work the trigger of your firearm without disturbing its felt or seen index on its target. Not only will this enhance the likelihood of getting hits, it will give you a mental shelter from fear in that crucial moment.



# 4 Tactics

---

*Be not afraid of any man no matter what his size;  
when danger threatens, call on me, and I will equalize.*  
Colt's Pt. F.A, Mfg. Co., 19<sup>th</sup>-century slogan

---

This truism has some merit, but if this is the gist of your sense of tactics, I'd like the chance to sell you my oceanfront condo in Tucson.

What are tactics, anyway? And how do they differ from strategy?

There are many definitions for both terms. I find a 1936 statement from Mao Tse-tung helpful in comparing the two terms. Mao was explaining how a small army of peasants could hope to conquer a vast land, fighting against superior forces. He said that while their strategy would pit one against 10, their tactics would pit 10 against one. This means that they tried to limit their fights to those in which they could muster an overwhelming advantage.

While the armed citizen who isn't out looking for trouble may not be able to muster a 10-to-1 advantage, tactics consist of making and taking every possible advantage in a fight or potential fight. Most firearms instructors cite the use of cover as a prime example of good tactics in a gunfight. It would be foolish not to use available cover. For one thing, if your assailant has the mental capacity to realize that you have effective cover and he doesn't, he may suddenly remember an urgent appointment elsewhere. The best strategy for the armed citizen is to win fights by avoiding them.

## DEFENSIVE USE OF FIREARMS

### CLOSE ENCOUNTERS

In most jurisdictions, drawing or even exposing a firearm requires the same justification needed to fire it at another person. This means that most fights that can't be avoided will start at one to two arm lengths. Thus, at this stage of the game your best tactics will probably involve movement, both to get out of the line of the most immediate threat and to buy time to draw your gun. If the threat is made with a gun, remember that the gun can only direct its force in a relatively straight line. If the gun goes off and you are no longer in front of it, its projectile can't hit you. In a similar manner, even if you don't have room to sidestep, if you have the training to deflect the gun so that the assailant's line of attack is the one that is moved, the same result is accomplished.

The same principle applies to threats made with other weapons, including body parts, but you must recognize that most of these other sources of harm often travel in arcs. The branch of the martial art of *wing chun kuen*, in which I was trained by Robert Chu, looks at the body as having two *gates* that can be entered in attack. The inside gate is the vertical space between the arms when they extend from the shoulders. The outside gate is the rest of the body. In general, moving to your assailant's outside gate gives you the greater advantage to limit his ability to carry through his attack. *Wing chun kuen* also emphasizes control of what we call the *centerline*, both your own and your assailant's. (The centerline is basically a vertical plane projecting from or to the spine, usually through the chest.) As described above, even if you don't move yourself to the assailant's outside gate, you can still access it by deflecting his centerline, which is also his strongest line of attack. Further, at this range you usually gain more control by moving into the assailant than by moving away, if you are able to use this principle.

Why this digression into a fairly esoteric Cantonese martial art in a book about firearms? Although the firearm may be a great equalizer in many circumstances, if you still believe that

## TACTICS

- (a) you can replicate your weekend-match 1.2-second draw from concealment while somebody is trying to take your head off and you're still asking yourself, "Is this really happening to me?";
- (b) the other guy can't remove your head and a few other things in that now somewhat elongated 1.2 seconds; and
- (c) firing your 96 percent one-shot-stop silver bullet into the heart of the vampire who's within a few feet will instantaneously cause him to cease all hostile activity and cancel all his body's momentum;

you need to contact me right away about that oceanfront condo in Tucson before someone else beats you to it. As I said earlier, the firearm covers only a narrow band in the spectrum of self-defense. You need to develop as many other defensive skills as your physical ability allows.

Getting back to our arm's-length encounter, I train my students to sidestep while deflecting the attack and to shout "Stop!" while simultaneously acquiring the grip on their holstered guns. However, if the assailant has a gun, it may actually be the easiest gun for you to access, if you know how to take it from him.

But wait! We have now introduced an additional tactic: the shout. When I discussed my experience of taking a hostile person at gunpoint with the late Jim Cirillo, he chided me for not having attempted to disorient the assailant with shouts. At the time of the incident, I was very conscious of the risk that engaging my mouth might slow my other, more crucial reactions. In retrospect, I can see that this was because my prior training hadn't conditioned me to issue those commands reflexively. The shout may not only stun and disorient the assailant, it could also draw the attention of potential witnesses, whom you may need down the road.

By now you may have generated the time and space to access a

## DEFENSIVE USE OF FIREARMS

gun, either yours or his. What do you do with it? If you thrust it out to acquire a sight picture, you may simply be placing it in your assailant's hands. The gun need not even extend far enough for a sight picture to place it within the grasp of your assailant. Even if the assailant doesn't get the gun away from you, he may deflect its line of fire. At this range it's very useful to have at least one protected-gun shooting position that will work for you, and preferably one that requires only one hand. Remember, you may still be in the process of deflecting his weapon at the time that you fire.

### WHERE TO AIM?

Next question—where to shoot? Most defensive firearms training emphasizes attacking the plumbing complex in the chest. As many big-game hunters can attest, a heart shot can still allow the animal to run a few hundred yards before dropping. I favor placing the first round in the pelvis, so long as you are using rounds that have the energy to damage heavy bone. The probable minimum energy for this is a +P .38 Special load. Although the bones of the pelvis may not shatter when hit with a high-energy round, Jim Cirillo reported that every felon shot in the pelvic area by members of the New York Police Department (NYPD) Stakeout Unit invariably fell to the ground.

I was originally trained to aim for the pelvis under three specific circumstances:

1. *Whenever holding someone at gunpoint.* Aiming at the chest will block your view of the assailant's hands. The eyes may be regarded as the windows of the soul, but the hands are usually the part of the body that will be used to do you serious bodily injury.
2. *When threatened with a contact weapon, such as a knife.* The rationale for this has already been explained: an assailant can't chase you very far if the structure that links his legs is in the process of breaking.

## TACTICS

3. *When shots to the chest have failed to produce results.* The assailant may be wearing body armor, which rarely extends below the belt. Although most instructors teach head shots as failure drills, these are much easier on stationary paper targets than on moving, hostile people. Further, only part of the head contains the brain, and bullets don't always easily penetrate that part.

I now train my students to use the pelvis as their initial aiming point when it is available, particularly at the relatively close ranges of most handgun engagements, so long as they are using a full-power handgun. There are two reasons I have expanded beyond the three circumstances. First and most important, every choice you have to make under stress slows you just a little more. If you always have the same response, you will respond faster. Second, not only does aiming for the pelvis give you a view of the assailant's hands, it also lets you keep him in your sights if he ducks or dodges. Many people with a lot more experience than I have, including Bill Jordan, have been fond of placing the first round in the vicinity of the belt buckle. So long as it goes no higher than the belt buckle and has sufficient energy, it is likely to strike pelvic bone. Even a low-energy load may

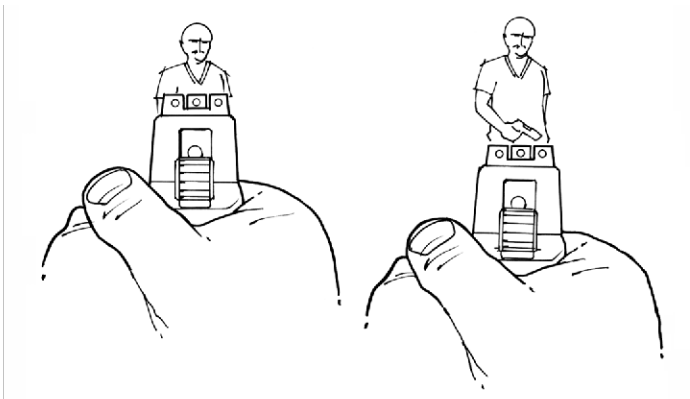

*Aiming at the chest can block your view of an assailant's hands. Aiming at the pelvis will usually leave them visible. (Illustration by Jeff Cahill.)*

## DEFENSIVE USE OF FIREARMS

still be deflected upward toward vital organs if it fails to penetrate the bowl-like bone structure at the far side of the pelvis. An additional benefit may be that a bullet striking heavy bone is less likely to go on to injure innocent parties in a crowded environment.

There is an important caveat to aiming for the pelvis: inexperienced or highly excited shooters may jerk their shots low and to the nondominant side. If you do this while aiming at the chest, your shot may go into the abdomen or the leg, depending on the distance to the threat. If you do this while aiming at the pelvis, you may miss altogether.

Dr. James Williams, who teaches a course in *tactical anatomy*, points out that when you have the space in which to see the pelvis prior to working the trigger, it is actually preferable to aim for the lateral pelvis. The reason for this is twofold. First, in the area between the groin and the hip joint, there is a large bundle of vein, artery, and nerve. A bullet rupturing one of those vessels will produce rapid loss of blood, and shock to the nerve is likely the reason that the felons shot in the pelvic area by the NYPD Stakeout Unit all fell to the ground. Second, the section of bone at the rear of the pelvis, between the fused section of spine known as the sacrum and the hip joint, is not only more vulnerable to ballistic damage than the heavier sacrum, but it also serves as a sort of bridge. This, in turn, increases the likelihood that the partial fracture caused by a bullet wound will spread, thus breaking the bridge, which would then lead to a collapse of the structure.

### HOW MANY SHOTS?

The next question is how many shots to fire. Many instructors teach something like two shots to the chest, lower the gun to assess, and one round to the head if the threat/target is still up. I have already mentioned my skepticism about making effective head shots on real, mobile, hostile people. I also disagree with pausing arbitrarily after two rounds. Unfortunately, the answer isn't a simple one.

If you have a single assailant, keep shooting until he is no longer an immediate threat. If you have recognized that there is more than

## TACTICS

one assailant, get one round into each of them before checking to see if any of them requires further doses of lead. Several years ago, a Texas police officer who had recently shot a “practical shooting” match got into a gunfight with three suspects. In match form he double-tapped the first suspect, double-tapped the second suspect, and then fell mortally wounded when the still-unscathed third suspect shot him.

If there is more than one assailant, you need to shoot the one who presents the most immediate danger first. It doesn't matter if one is armed with a shotgun and another is armed with a .25 auto, a knife, or merely a very large body. If the guy with the shotgun doesn't have it indexed on you and one of the others presents a more immediate threat, the guy with the shotgun shouldn't be your first target. If you are faced with more than one assailant and all seem to provide a threat of equal immediacy, I advise shooting the one(s) on your gun side first. The reasoning behind this is that guns, gun hands, gun-side arms, and gun-side shoulders tend to get shot in gunfights. It will be easier to remain in the fight if your primary gun hand is still functioning than if you have to switch to your secondary gun hand. After the first round you have the option of continuing to aim for the pelvis if the assailant is still a mobile threat or placing additional shots in the chest cavity if the assailant still threatens you in some other manner.

If you have only perceived one assailant and he has fallen after taking a few hits, you still need to make a quick 360-degree scan to make sure that he doesn't have a partner approaching from an unseen angle. In the process, see if there is some available cover. Even if you don't see any cover, move! If the original assailant is faking or was only briefly stunned, you don't want to remain in the place where he last remembers seeing you. Some people call this “shoot and scoot.”

## COVER AND CONCEALMENT

Understand that cover means something that stops bullets, while concealment is something that keeps you from being seen. Cover

## DEFENSIVE USE OF FIREARMS

usually provides concealment if it is large enough, although the Lexan panels protecting the tellers in the banks in many large cities provide cover with no concealment at all. Cover can be relative; something that stops common handgun rounds may not stop high-power rifle rounds. Cover may also be relative in the sense that improvised cover is usually temporary. You can be outflanked while you are behind limited cover, particularly if you have more than one determined assailant. If you have had to take cover outside your home or some other location that you may have prepared to defend, you need to be thinking about your next piece of cover. On the street, cover is likely to be narrow: a fire hydrant, a utility pole, the space behind the wheel and tire of a parked vehicle. Sometimes it may be very low, such as a parking block or a curb.

Concealment can be very useful if it allows you to leave the scene unobserved or, if it is a scene that you can't leave, to get the drop on your assailant. Realize, however, that concealment is a visual concept. If you make noise while moving down a hallway in your home, the intruder may not see you but he can definitely hear you, and it is not unknown for inconsiderate people to fire through wall-board or bushes at a mere sound. The photos in gun magazines of the homeowner taking cover in the doorway of the master bedroom are bunk—most interior walls won't stop even a .22 round. A portion of your body may project beyond cover when you have to shoot back without negating the cover that protects the rest of your body. When a portion of your body visibly projects beyond mere concealment, all concealment is negated because your location has been revealed. The seemingly concealed portion of your body is vulnerable to gunfire. Another issue that must be considered is whether you cast a shadow that reveals your position by projecting beyond the edge of your presumed concealment.

At this point you may have figured out that there is no absolute rule about using cover or concealment because there is rarely absolute cover or absolute concealment. It is usually preferable to use cover when it is available, so long as it doesn't glue you to one spot. Your

## TACTICS

cover can vanish as your assailant moves to a different angle. When you are able to take cover in a situation where you cannot be readily outflanked, that cover may allow you to dominate the situation without having to fire a shot. When you are somewhere like your own home, where you can limit the avenues of attack, you may be able to create cover where you can remain safely for a prolonged period.

Another tough decision that you may have to make under the worst of circumstances is whether it's best to run for cover or to shoot first and then move to cover. This will depend on the nature and distance of the threat and the distance to the cover. If the threat is close to you and the cover is not, it is probably wiser to shoot first. If the cover is only one or two steps to your side, it's probably better to concentrate on reaching cover first. These issues may be further influenced by whether the threat is made with a firearm or some other weapon. You might be able to outrun someone with a knife or a brick under the right circumstances, but you won't outrun a well-aimed bullet.

At distances of a few arm lengths, your assailant won't need much skill to shoot you if you are moving straight back. It is tougher for him to hit you if you're moving laterally to him. Most of the time, bad guys with handguns don't hit good guys and girls much beyond 20 feet, but you can't afford to bet that your assailant is not one of the few who is a skilled shooter. Although it's not too tough to hit stationary targets on the range while moving laterally to them, if you have to shoot while moving laterally to an assailant who is also moving, it is probably best to step, shoot, step, shoot. If you're stepping toward cover, this tactic can be viewed as a compromise between shooting first and getting to cover first. You may even think of this as a case of using your gunfire as improvised cover, as long as you make sure that it hits its intended target and not something else. If your assailant is forced to keep his head down, he can't aim at you.

When cover is behind you and off to one side, the fastest way to reach it is to run directly to the point where you will take cover. When cover is forward and to the side, the best choice is to move to the side, getting some cover between you and the threat; you can then turn, like

## DEFENSIVE USE OF FIREARMS

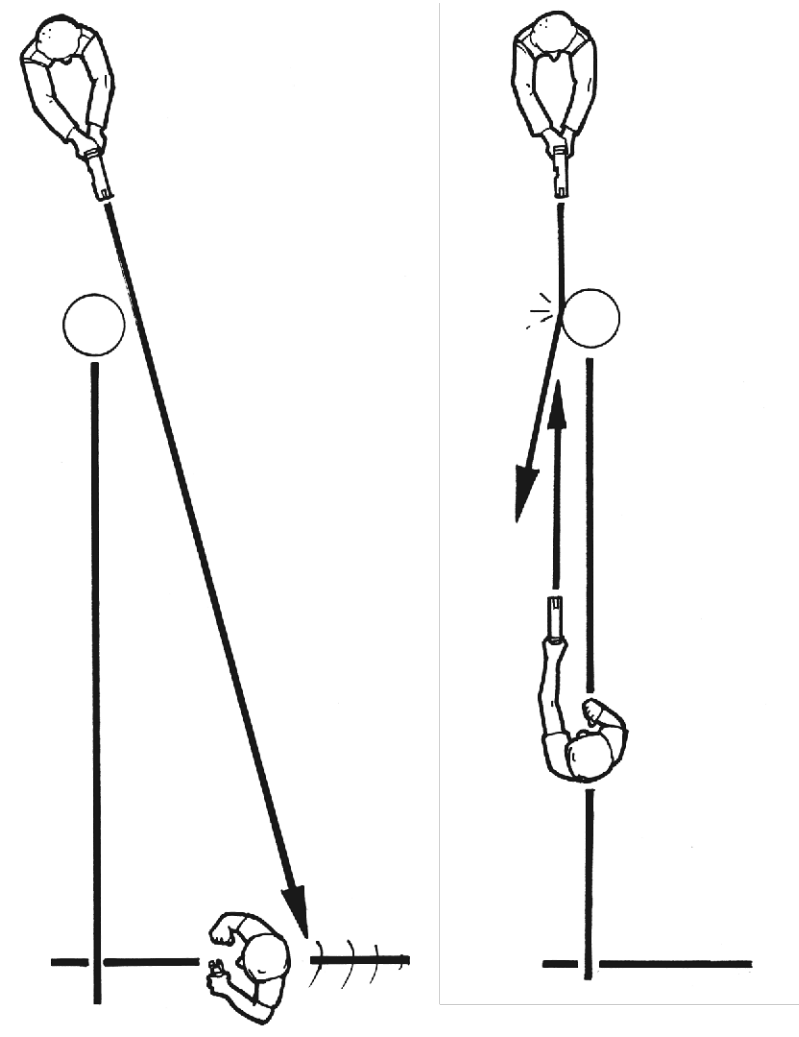

*When moving to cover that is in front of you but off to one side, first move laterally to get the cover between you and the assailant. You can then move closer to the cover if necessary. (Illustration by Jeff Cahill.)*

## TACTICS

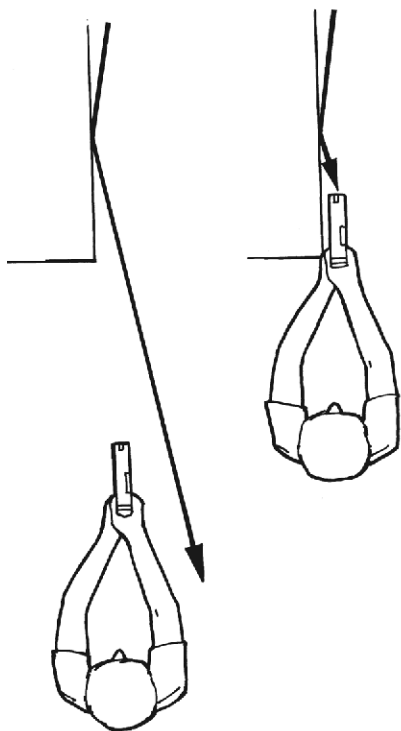

*Placing yourself too close to cover may also place you at risk of being struck by rounds “skipping” off a hard, flat surface. (Illustration by Jeff Cahill.)*

the bend in an “L,” and move forward to get more cover if you need to. This tactic is known as the FLETC “L” because it was popularized by the Federal Law Enforcement Training Center (FLETC) many years ago.

The latter point raises the question of how close you should get to cover. Again, there are no absolutes. Some people, particularly those with a background in competitive shooting, where targets are stationary and don’t shoot back, like to use cover for support. This requires you to get quite close to the cover. Others are concerned that if the cover is something like the corner of a building, it may present a perpendicular surface from which bullets can “skip” into you. Unlike light, where the angle of reflection is equal to the angle at which the light strikes the surface, bullets tend to skip off at about 12 degrees,

regardless of the oblique angle at which they strike. In this scenario it is preferable to be about 6 feet behind the cover so that skipping bullets will fly past you. However . . .

You have more flexibility staying about 6 feet behind cover if it is tall enough to permit you to stand. While you stand it is fairly easy to shift your position, either to avoid the shifting movements of your assailant or to carefully seek him out by “slicing the pie,” gaining an-

## DEFENSIVE USE OF FIREARMS

gular increments of your field of view as you get closer and closer to the edge of the cover. If you have to kneel or go prone, you give up mobility, and it is probably safer to get closer to the cover. If it is dark and you need to use a flashlight, standing back from cover may illuminate you when the edges of your flashlight beam reflect off the cover. In this scenario, you are better off getting very close to the cover so that the spillover from your beam of light can only reflect off the side of the cover.

Speaking of kneeling behind cover, there is the question of whether to shoot over low cover or around it. Shooting over low cover gives you a wider field of view at the expense of more exposure. Shooting around low cover gives you better protection at the cost of reduced visibility. The initial visibility from shooting around low cover doesn't differ significantly from shooting around the side of tall cover. However, if the cover is tall, you can retain mobility by remaining standing. It isn't very easy to walk on your knees.

A common form of low cover is the front wheel of an automobile. Not only do the rim and tire give you some cover, the engine block usually sits between the front wheels. When you shoot over the

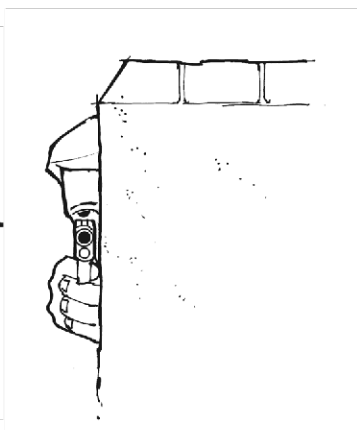
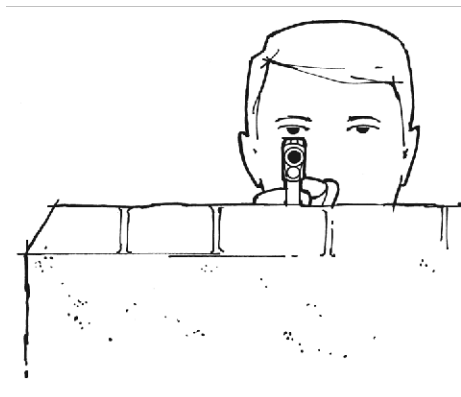

*Shooting over low cover gives you more visibility at the cost of more exposure. Shooting around low cover reduces your visibility but also reduces your exposure. (Illustration by Jeff Cahill.)*

## TACTICS

hood, however, you are usually going to be shooting over a somewhat domed surface. The problem with this is that your line of sight is higher than the axis of the bore. This poses the risk that you may skip your bullet off the curved surface of the hood if you don't realize that it crosses the axis of the bore. This risk is greatest with a firearm like an AR-15, whose line of sight is about 3 inches above the bore, but it has happened with handguns. In this scenario, it is best to place the hand or hands that support the gun on the horizontal surface to elevate the bore enough to clear the curved surface of the hood, even if it means greater exposure—skipping the bullets who-knows-where won't win the fight for you and may injure innocent parties.

There may actually be scenarios where you would kneel behind tall cover. If you have fired some rounds around the corner of a building and have to step back to reload, it is not a good idea to return to the same firing position if the fight is still on. Your assailant may be waiting, with his gun already aimed at the spot where he expects a portion of your head to reappear. However, if you were standing before your reload and he anticipates that you will still be standing when you reappear, he may not see you in time if you reap-

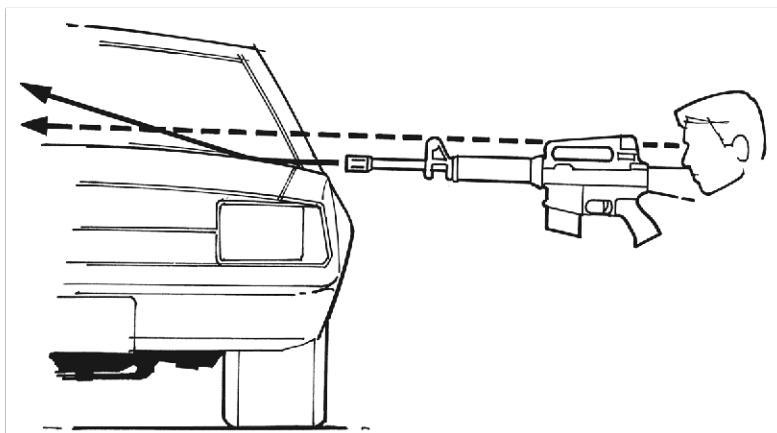

*When shooting over a domed surface, you may appear to have a clear shot when the bullet will actually strike that surface. (Illustration by Jeff Cahill.)*

## DEFENSIVE USE OF FIREARMS

pear in a kneeling position. This is because the complex of his hands and aimed gun blocks his view of your lower position. If you must reappear from the same side of the same piece of cover, it is preferable to do so at increasingly lower positions. Of course, if you have the option to reappear from the other side or someplace entirely different, that would be better yet.

Note that all mention of kneeling and prone positions has been in conjunction with cover. Poor shooters often jerk their shots low. At intermediate ranges, kneeling or going prone in the open could place your most vital organs in the line of the shot jerked low. At longer ranges you could fall victim to the bullet-skipping effect that was discussed in terms of walls; the same phenomenon can occur with hard horizontal surfaces, such as streets and sidewalks or even packed dirt.

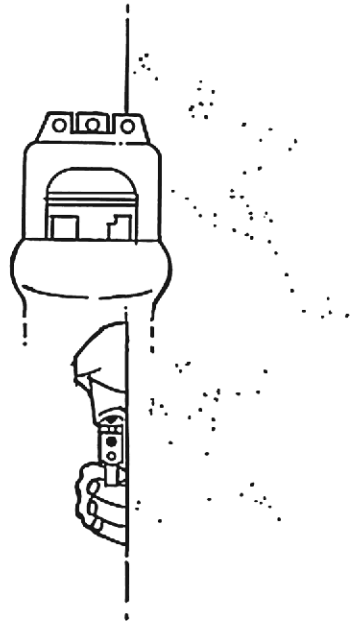

*If you must reappear from the same side of cover, do so at a lower level; if the assailant is aiming where he last saw you, he may not see you in time. (Illustration by Jeff Cahill.)*

### LOW LIGHT

Low-light tactics can be a very complex topic. Complexity comes partly from the fact that we rarely find ourselves in complete darkness; we are more likely to find ourselves in gradients of light. If there is more light behind you than in front of you, you will likely be highlighted to assailants to your front. If there is less light behind you

## TACTICS

than there is around your assailants, they may have trouble seeing you, but you may see them.

Further complexity stems from the level of sophistication of available equipment and your degree of training and experience operating in reduced light. For example, if you must use a flashlight to seek out the threat or to verify its identity, you will reveal your location. However, if you have access to night-vision devices and know how to use them, you may be able to see your assailants without their seeing you. I will assume that most of us do not have access to the night-vision devices and don't have the time to remain sharply honed in low-light, special-operations techniques.

A very simple rule says, "When you're in the dark, stay in the dark; when you're in the light, light up the dark." This means that if you are in relative darkness and you turn on your light, you reveal your position. If you are in light, relative to darker areas, you're already visible to people who may be hiding in those darker areas. In such cases you lose little by illuminating those dark spots to ferret out your assailants.

There is value in this rule, but it doesn't deal with all situations. Among complicating factors are horizontal and vertical structures, including the horizon, building corners, and doorways. Your relationship to these will help determine if you are in relative light or relative shadow. This is most crucial when you have to move. If you are on a preplanned mission, you can anticipate some of these situations and adjust accordingly. When trouble comes looking for you outside of your home, you may not have that luxury.

I have mentioned that your own gunfire can provide a limited form of improvised cover while you are moving. Your lighting equipment can similarly provide a limited form of concealment, in the sense that your assailant won't be able to look through a bright light to see you. However, your assailant will have a pretty good idea that you are somewhere behind the light, particularly if it is obvious that it is a handheld light. This means that you may be able to use momentary flashes of light to temporarily blind your assailant while you

## DEFENSIVE USE OF FIREARMS

move quickly to another location. Keep in mind that if you are dealing with more than one assailant, the beam of light that blinds one may only signal your location to another. Your use of light should not be continuous, and it should be interspersed with quiet movement. You should try to avoid predictable patterns in your movements in the dark between the flashes of illumination, because your location moments earlier will already have been revealed.

Another area of possible concern is that while modern flashlights have the advantage of very bright light from a small package, the bulbs don't go completely dark the instant you switch off the light. If you are dealing with only one assailant and he has just had the beam of your light in his eyes, he won't see the brief glow of the newly extinguished bulb. However, if there may be more than one assailant in the area, you may want to consider moving the switched-off light in the opposite direction from where you intend to move or pointing the briefly glowing bulb down for a moment as you initiate your movement.

Flashlights aren't the only possible source of light that you may be able to control. Some instructors counsel the use of remote-control switch systems that may allow you to illuminate intruders in your own home. One friend advises the use of strategically placed nightlights. Both are good ideas, so long as there is no interruption in your electrical power. A good "plan B" is the use of chemoluminescent sticks, such as Cyalume Nightsticks. They don't require electrical current or batteries. Unlike such dubious techniques as rolling flashlights across the floor of doorways, these lightweight sticks can be tossed around corners. I prefer to use red ones because exposure to red light has little or no effect on your own night vision.

### REFLECTIONS—FRIEND OR FOE?

Another visual concept that can work for you and against you is reflection. You can use reflections to increase your field of vision, such as checking the reflections in store windows as you walk down the street. You can place conventional mirrors or con-

## TACTICS

vex mirrors at key points in your home to help you spot intruders before they spot you. The other side of this coin is that there are many reflective surfaces, including TV screens, that an intruder may use to spot you moving within your home. One low-light issue that may not be readily apparent is that the eyeglasses many of us wear may reflect light even in a relatively dark environment, signaling our presence or movement. Friends with extensive military experience assure me that they have spotted the reflections of night sights in soldiers' eyeglass lenses.

### BE READY TO IMPROVISE

Tactics are not absolute. Many can be improvised, such as throwing an object to distract the assailant or even holding up an opened newspaper to confuse an assailant with a gun. It is very useful to play the "what if" game to prepare for a variety of situations that you may encounter, but it is unlikely that you'll be able to anticipate every single possibility. You need to condition the skills and reflexes for the techniques you may need, but you have to remain flexible mentally. Further, to quote the immortal words of Inspector Harry Callahan, "A man's got to know his limitations." What may seem like a good tactic while you mull it over in your armchair may not work if it demands more skill than you have developed or if your selected equipment isn't appropriate to the task.



# 5 Skills

---

*Age and cunning beat youth and skill.*

---

As in most witticisms, there is an element of truth in this statement. It is misleading, however, because it substitutes the concept of cunning for that of skill, implying that skills are based only on strength and speed. There are really countless skills in life. Some are easier to master and retain when you are young; others get substituted when you can no longer compete successfully against the young in their preferred games. Of the countless skills in life, a great many can relate to preserving your physical well-being. This discussion deals with some of those that involve firearms.

## **TRIGGER CONTROL**

The basic elements of marksmanship include position, sight alignment, sight picture, trigger control, and breathing. Most defensive engagements occur at ranges where trigger control is the most important element of being able to hit your selected target. If the motion of working the trigger pulls your gun out of alignment, your shot won't go where it was initially aimed, whether that aim was accomplished by body position, use of the sights, use of some other visual index, or a combination of those factors. Regardless of whether the trigger has a short or long travel, the trigger must be moved

## DEFENSIVE USE OF FIREARMS

smoothly, like the clutch on a vehicle with a manual transmission, to get dependable results.

Trigger control is primarily the result of lots of safe dry-fire practice. An arguably secondary element of trigger control is ergonomics—if you can't get the right amount of finger on the trigger to operate it efficiently, you will likely disturb the alignment of the gun when you fire. Many years ago, the instructors at Chapman Academy made the observation that the greatest accuracy with a handgun was associated with the middle bone of the trigger finger being perpendicular to the axis of the bore at the time that the hammer or striker is released. This condition is determined primarily by the relationship between the size and shape of the hand to the size and shape of the handgun. Depending on the gun, this relationship may be adjustable by changing the grip stocks on the gun, swapping the grip module, re-contouring the trigger, or fitting a trigger designed for smaller hands. Often it is best accomplished by purchasing a better-fitting gun. Some adjustment can be obtained by shifting the position of the gun in the hand.

Trigger control is also influenced by the smoothness of the trigger's travel. Dry-fire can, within limits, smooth out minor hitches in the trigger action. Some guns may require the attention of a gunsmith skilled in "action jobs" on the model of gun in question. Although some people argue that the best finger placement for double-action triggers is with the crease of the farthest joint at the outside edge of the trigger, many others do better placing the pad of the finger on the trigger, as is usually

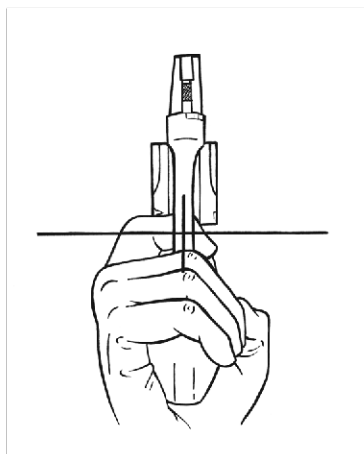

*You may get the best accuracy from a handgun if the middle bone of your trigger finger is perpendicular to the bore at the time the hammer falls. (Illustration by Paige Robbins.)*

## SKILLS

advocated for single-action triggers. The former position gives more strength, while the latter may give more precision. Dry-fire develops more of both. Dry-fire, by the way, should be practiced with both the dominant and nondominant hands.

Another concept that improves trigger control is to make it a habit to *reset* the trigger. This means that as you release the trigger you should let it go forward only until you feel it click. On autoloading firearms this occurs as the sear resets for the next shot. Even on double-action revolvers there should be a sensation that the trigger has reached the end of its forward travel. While some instructors argue for this because it eliminates unnecessary trigger travel, especially on single-action autoloaders, I argue for it because it ensures consistency both in your trigger stroke and your grip on the gun. On a handgun, in particular (most of us don't have regular access to sub-machine guns), consistency of grip ensures a similar recoil arc from shot to shot. The gun is actually in recoil before the bullet leaves the barrel. When you first start training to reset the trigger, you likely won't do it until the gun has returned from its recoil. As you develop the skill, you'll be able to reset the trigger as the gun returns from recoil. In general, it should take you as long to release the trigger as it did to press or roll it back to fire the shot.

At the other end of the spectrum from resetting the trigger is letting the finger fly off the trigger as soon as the gun fires. In many hands, this has the effect of relaxing the grasp of the gun enough to induce malfunctions with autoloading pistols.

## SHOOTING POSITIONS

Shooting positions have been the basis of countless debates and feuds in the world of gun writing and firearms instruction. I believe that the most important element of shooting positions with handguns is the wrist of the gun hand. The wrist can bend up, down, in, or out; it can rotate in various combinations of these directions. The wrist doesn't really lock until it is forced to the extreme of one of these di-

## DEFENSIVE USE OF FIREARMS

rections, but it does have a central position of greatest stability under muscle contraction. When the wrist is used to make adjustments in aiming, it ends up returning to its strongest position at the time the trigger is actuated, particularly if there is any anticipation of recoil. Therefore it is crucial to index the handgun toward its intended target with the wrist in its strongest position.

The next concern with a handgun is how the barrel aligns when the gun is grasped. Tradition dictates that the barrel should align with the bones of the forearm. This tradition probably dates back to the time of dueling with pistols, when the shooter's body was turned sideways to the threat to minimize the target presented. In this position the head is turned to the gun side, and the aiming eye looks directly down the extended arm. Thus, it is logical for the barrel of the gun to continue along that same line. In traditional bull's-eye shooting, the body is typically rotated about 45 degrees away from the target. Although not as crucial here, the barrel alignment with the forearm should not present a challenge to the shooter whose master eye is on the same side as the primary gun hand since there is still going to be some rotation of the head. Alignment with the bone structure of the forearm will probably improve recoil management in this one-handed discipline. Both examples, however, are preplanned, formalized situations.

In defensive shooting, we are more likely to face our assailant

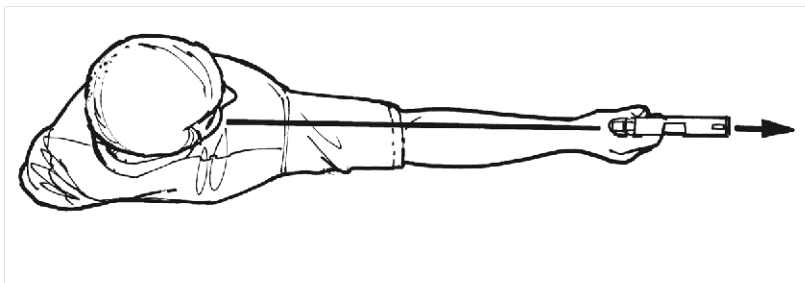

*It made sense for the bore to align with the bone structure of the arm when people shot from the dueling position. (Illustration by Jeff Cahill.)*

## SKILLS

relatively “squarely,” meaning that both shoulders will be similarly distant from the perceived threat. We may do this instinctively to place our poorly defensible backs farthest from the threat. In these positions, regardless of whether the gun is held in one hand or two, we usually bring the gun to our midline, so long as the distance exceeds a couple of arm lengths. Bringing the gun to the midline tends to place the thumb of the hand grasping under the nose, which will usually place the gun itself in line with the eye on that side.

Assume, for the moment, that you have used a two-handed hold with both arms fully extended. This means that your arms will approximate the legs of an isosceles triangle, with your chest forming its base. Your line of sight will very closely parallel the altitude of the triangle, but if the barrel of the gun is aligned with the bones of your

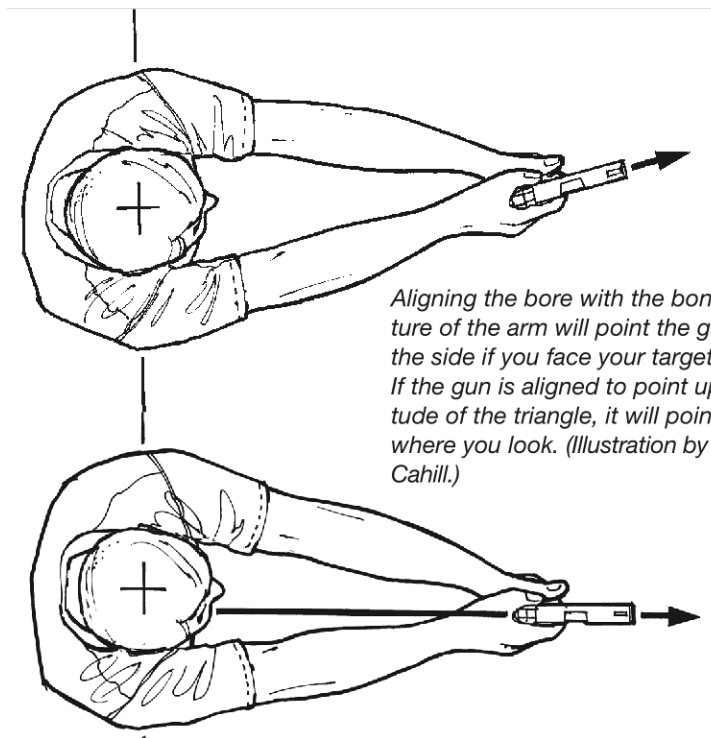

*Aligning the bore with the bone structure of the arm will point the gun off to the side if you face your target squarely. If the gun is aligned to point up the altitude of the triangle, it will point naturally where you look. (Illustration by Jeff Cahill.)*

## DEFENSIVE USE OF FIREARMS

forearm, it will extend the leg of the triangle past its apex, pointing off to your nongun side. This, in turn, means that if you are focused on the threat, the shot is likely to go wide, to your nongun side. If you are able to focus on the sights or some other element of the gun, you will need to cock or rotate your head and get your body rotated to the gun side some 20 to 30 degrees in order to get the gun properly aligned with the threat.

A better alternative is to grasp the gun so that it points along the altitude of the triangle, perpendicular to your chest. This means that if you are holding the gun in your right hand and you hold your arm directly in front of your shoulder, the gun points off to the right. However, when you swing the arm to your midline so that the gun is in front of your sternum, the gun points straight forward, where you are looking. Thus, if you trigger the round while focused on the threat, your shot should do okay on windage (horizontal axis), even if slightly off in elevation (vertical axis). If you take an instant to acquire the sights, it should take a minimal amount of head motion to get a proper alignment.

For most people, this alignment of the gun in the hand will occur if the back strap of the handgun is placed in the crease that occurs when you try to point your thumb in the same direction as your little finger. (This crease often corresponds to what palm readers call the lifeline.) This grasp of the gun may also give you better leverage on the trigger, particularly if it is a double-action trigger with correspondingly longer travel. If you grasp the gun in this manner, you tend to point it where you are looking, whether you use one hand or two. In the latter case it shouldn't make a significant difference if both arms are fully extended or slightly flexed, one arm extended with the other arm flexed, or both arms flexed to different degrees. Which of these positions is best for you is an individual matter that will be discussed shortly.

One last point about your grasp of the gun: you want your hand to go as high as practical on the gun's grip area. This moves the bore axis lower into your hand and reduces the leverage that the gun has to raise its muzzle in recoil.

## SKILLS

The most likely reason that so many firearms instructors teach their own particular shooting position is that they have found a position they believe works best for them. My experience is that no one position works best for everyone and that different firearms, particularly handguns, may be more amenable to different positions even for the same user. Some people may even find that one position may work better with the gun in the dominant hand and another when it is in the nondominant hand.

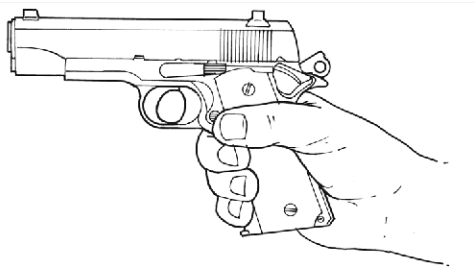

*If you leave a space between the web of the hand and the tang of the grip, the muzzle will “flip” higher in recoil. If that gap is closed, your hand gains leverage to better control the gun. (Illustration by Jeff Cahill.)*

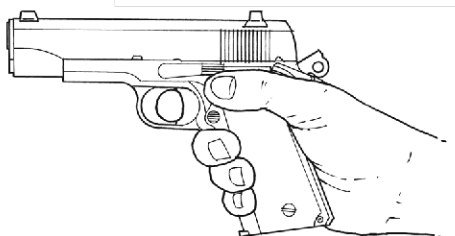

I lean toward defensive shooting positions that don't require major head movement to acquire the sights of handguns and allow the shooter to address the threat relatively squarely, in stances that do not inhibit movement and are not totally dependent on foot position.

For many years I was skeptical of the competition-derived isosceles (CDI) positions for handguns, in which both arms are slightly and equally flexed. I finally tried the CDI with a large-caliber autoloader, and I was favorably impressed. I find that it works very well for some of my students, including some with limited strength and skill. The

## DEFENSIVE USE OF FIREARMS

CDI, however, is somewhat dependent on the nongun hand having contact with the grip area of the handgun. With an autoloader this means that there must be a gap between the tips of the fingers of the gun hand and the “drumstick” of the thumb, also known as the thenar eminence, when the pistol is grasped. This, in turn, requires that the gun-hand thumb not curl downward to impinge on this space. This space is crucial because the effectiveness of the CDI with an autoloading pistol is enhanced when the thenar eminence of the nongun hand firmly contacts the grip panel at this location. CDI shooters usually shoot autoloaders with both thumbs pointing forward, with the gun-hand thumb resting on the nongun-hand thumb; this tends to maximize the nongun-hand contact with the gun and usually allows

the edges of the bases of the thumbs to come together. In this manner, the hands encircle the grip area of the gun like a partly open clamshell.

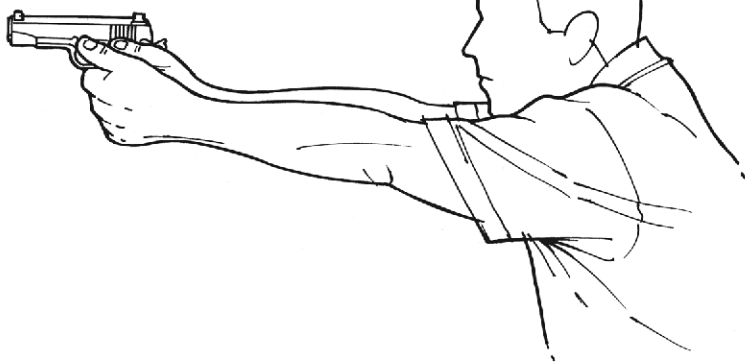
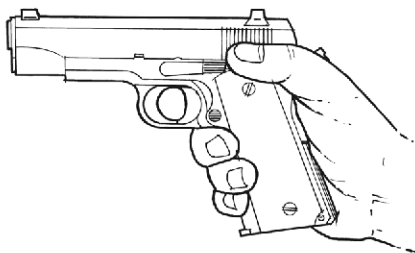

*If the gun-hand thumb is placed high, relatively parallel to the bore, a space is left for the optimal placement of the nongun hand in the competition-derived isosceles shooting position. (Illustration by Jeff Cahill.)*

## SKILLS

Most double-action-revolver shooters do better with the gun-hand thumb curled down. This, coupled with the shape of the grip frame of most revolvers, eliminates the contact space for the thenar eminence of the nongun hand. Revolver shooters who use the CDI in competition usually use grip stocks that project below the area covered by the gun hand. In this manner, the hypothenar eminence (the portion of the base of the palm across the “lifeline” from the thumb, or underneath the pinkie) of the nongun hand establishes contact with the grip area. Such “race gun” grip stocks aren’t compatible with concealment for people of average size or smaller.

I find that I tend to drop the nongun-hand elbow slightly toward the ground when shooting revolvers. With the exception of the alignment of the gun in my hand and the fact that I don’t wrap my support-hand thumb around the back strap of the revolver, I find my



*Both guns are Smith & Wesson N-frame revolvers with 5-inch barrels. The top one is fitted with an “Ichi Grip” from Hogue Grips for competition use, the other with Boot Grips from Craig Spegel for concealed carry. (Photo by author.)*

## DEFENSIVE USE OF FIREARMS

shooting position with these guns closely resembles the original “Weaver stance,” as shot by the late Jack Weaver. Since most of my revolvers have grip stocks that don’t project below the bottom of the grip frame, it is the adjustment of the position of the support hand, in order to close the gap between the bases of the thumbs, that lowers the elbow on that side.

I mention the difference between the grasp of the autoloading pistol and the revolver to emphasize that technique must be adapted to fit individuals and equipment. The degree of flexion in my elbows, for example, varies with the handgun that I’m shooting at the time.

---

After years of watching students repeatedly regripping with the nongun hand between shots, I am now convinced that it makes the most sense to establish the position of the nongun hand by

---

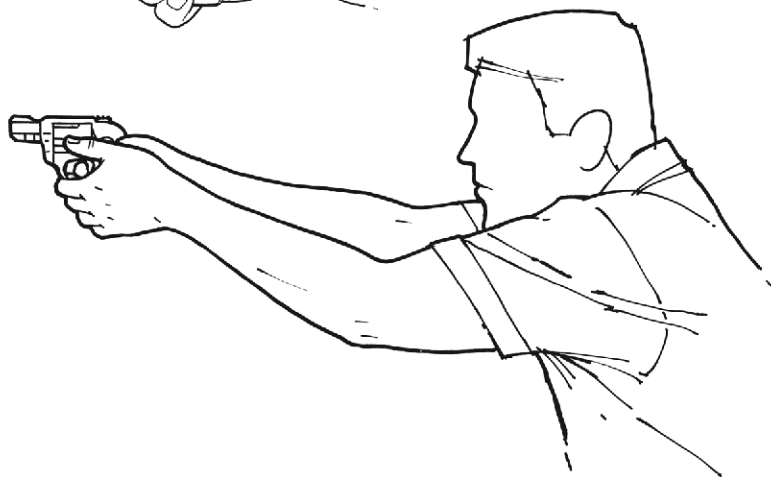
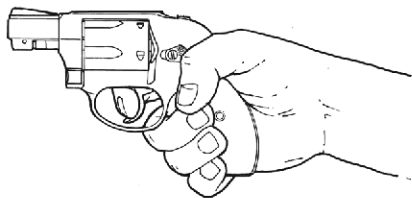

*Double-action revolvers are fired more efficiently if the gun-hand thumb is bent downward to “lock” into the middle finger. Subsequent adjustment of the contact between the bases of both thumbs may result in the nongun-hand elbow being flexed more sharply. (Illustration by Jeff Cahill.)*

## SKILLS

starting with the contact at the bases of the thumbs and then letting the fingers of the nongun hand settle into the “grooves” between the fingers of the gun hand. Because the bones in the palms of the hands are called metacarpals, I remind my students to “*marry the metacarpals*” of the thumbs by keeping them pressed together. Many shooters do best and, arguably, may be best prepared for high-stress situations by fully extending both arms until the elbows are locked. I shot this way for years and found that I didn’t shoot as accurately and that I developed referred nerve pain in my elbows as a result. Many others who shoot that way aren’t troubled with referred nerve pain and find that they shoot more accurately in that position.

If I ever find myself trapped in a seat behind a table and have to shoot farther than just across that table, there is a good chance that I would fully extend both elbows in order to lay my arms on the table. If I were to find myself in a confined space, such as between two buildings or other large objects, I might have to flex my elbows more sharply than usual. Technique must also adapt to conditions. For this reason, it is advisable not only to learn a primary technique that works best for you but also to learn how to use other techniques, even if they don’t seem to work quite as well. This leads us to our next point.

Our discussion so far has focused on shooting handguns from standing positions, using two hands, with sufficient space to obtain a visual index on the gun. U.S. law enforcement experience suggests that at least half of quick-reaction shootings occur one-handed, particularly at ranges less than 7 yards. Whereas larger grip areas may be advantageous for CDI shooters, grip frames with less girth allow the one-handed shooter to get a more secure grasp on the gun, which, in turn, gives better control of the gun. Some anatomic insight can also increase one-handed control of the handgun.

When the arm is sharply flexed, as in a protected-gun position, the best musculoskeletal alignment occurs when the hand is rotated outward (supinated) between 20 and 30 degrees. For the right-handed shooter this means that the sights would be oriented around 1 o’clock. If the hypothenar eminence (or the outer inner edge of the

## DEFENSIVE USE OF FIREARMS

bottom of the grip frame, if that projects beyond the hypothenar eminence) is pressed against the rib cage, this supination not only increases control of the gun, but it also indexes it toward the midline and, in the case of an autoloader, creates the space necessary for the slide to cycle reliably.

As the gun is pushed out toward its sighting plane, the strongest position shifts to that with the sights oriented to 12 o'clock, so long as the arm is short of full extension. Once the arm reaches full extension, however, the strongest position is with the gun rotated inward (pronated) about 20 to 30 degrees, with the sights around 11 o'clock for the right-handed shooter. Shooters who fully extend the arm when shooting one-handed may find one or more advantages from this pronation: better recoil control, better trigger control, and better alignment of the sights with the eye. Others may prefer leaving the sights at 12 o'clock.

Regardless of whether it's a handgun or a long gun, the best way to manage recoil is to make sure that your shoulders are forward of

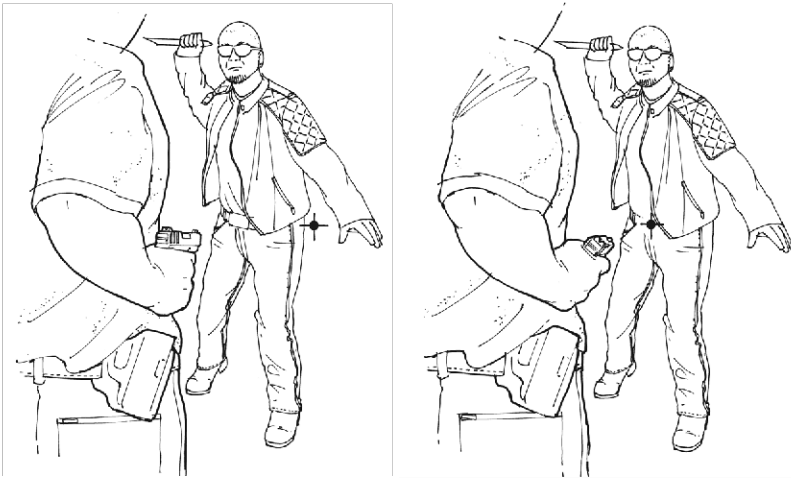

*Holding the sights straight up in the protected-gun position sends the shot wide. Rotating the sights outward 20 or 30 degrees centers the shot and also provides clearance for the movement of the slide. (Illustration by Jeff Cahill.)*

## SKILLS

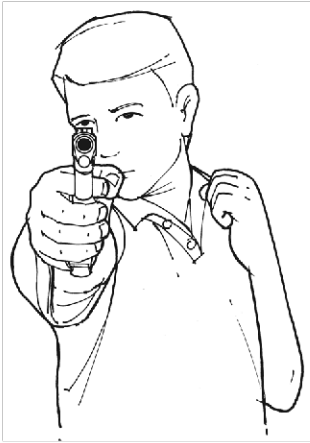

*Holding the sights straight up when firing one-handed may require rotation of the head to access the sights. Rotating the sights inward 20 to 30 degrees may eliminate the need to rotate the head and may provide other ergonomic advantages. (Illustration by Jeff Cahill.)*

your hips when you fire. A further advantage of positioning yourself this way is that it minimizes the leverage of the gun to push you off balance, thereby reducing your tendency to anticipate the shot and push it lower than your point of aim. This position is easily accomplished by relaxing the ankles, knees, and hips with a slight forward lean, but not enough to put yourself off balance. In this way you'll be in a stable shooting position if both feet are side by side or if one is forward of the other. While most people shoot best with the nongun-side foot slightly forward, you may not always have that luxury, especially if the shot has to be taken while moving.

### SHOOTING WHILE MOVING

Many instructors teach how to shoot while moving straight forward and straight backward. These are not particularly difficult skills to develop once you have learned the fundamentals of trigger control

## DEFENSIVE USE OF FIREARMS

and aiming. If you take into account that walking is a series of controlled falls, you can appreciate that each fall tends to disturb the muzzle's alignment with the target. By increasing the flexion in the ankles, knees, and hips as we just discussed, you introduce some shock absorption into each of the falls, lessening the disturbance of the muzzle's alignment with the target.

Keep in mind that in the real world there won't be much call for shooting while moving forward, unless you are part of a tactical entry team, have to reach a downed or captive partner, or have to escape down a building corridor. Similarly, it doesn't make much sense to shoot while moving straight backward unless you have to make an escape down a corridor or shoot while dragging a downed partner to safety. In the latter case, rather than stepping symmetrically to the rear, you will likely do better by using a *drag step*. Assume that you have a handgun in your right hand and are dragging your partner with your left hand. This already places you in a pronounced forward lean. Step back with the toe of your right foot, drag yourself (and your partner) back to your earlier stance, and then repeat.

If you have developed one-handed shooting skills, you should be able to shoot while doing this. We already discussed more tactically sound lateral movements in the previous chapter.



*On a good day, this 60-year-old, 4-foot-11-inch woman can rack the slide of her pistol without help. By relaxing and leaning on the gun, she already has the sights back on target while the ejected case is near the top of its trajectory. (Photo by author.)*

## LONG-GUN SHOOTING POSITIONS

Long guns have traditionally been shot in standing positions

## SKILLS

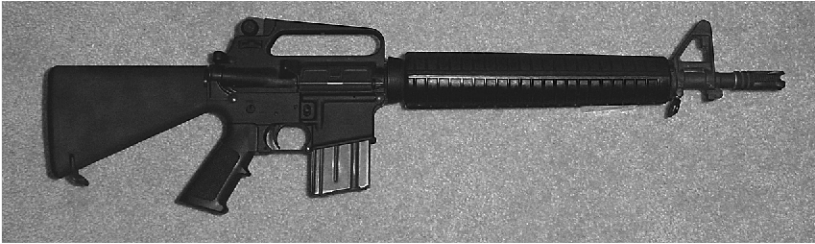

*A “stubby” stock or a telescoping stock that is not fully extended may make it easier for some people to shoot a long gun from a less bladed stance. (Photo by author.)*

from bladed stances (gun shoulder significantly behind the nongun shoulder) with the gun-hand elbow elevated at least to a horizontal position. Target shooters blade themselves to their targets to shift much support to the skeletal structure while minimizing muscle tension, thereby reducing tremor. Defensive long-gun engagements usually occur at distances significantly shorter than city blocks, reducing the need for 100-yard X-ring accuracy.

Blading the stance minimizes the amount of shoulder behind the butt of the gun, requiring elevation of the elbow to restore the shoulder pocket in the groove between the pectoral and deltoid muscles. In the process the pectoral muscles are extended, making them more sensitive to heavy recoil, such as may be produced by a shotgun. Using a position that is more square to the target (which may require a shorter stock) allows the shooter to lower the elbow, contracting the pectoral muscles and making them more recoil resistant. The lowered elbow does not project as far beyond cover and is not as vulnerable to getting bumped while navigating through narrow spaces, such as doorways.

Moving is also more natural when your body is fairly perpendicular to your direction of travel—we normally walk symmetrically. Many shooters find that they handle long guns more efficiently if only the toe (lower corner) of the butt is placed in the shoulder pocket. This minimizes the degree to which the head must be tilted to acquire the sights and also minimizes felt recoil. Other shooters pre-

## DEFENSIVE USE OF FIREARMS

fer to place the entire butt against the shoulder. This difference is probably a function of different body shapes.

Additional shooting positions—such as sitting, squatting, and kneeling—can be performed with the upper body in the same configuration as in standing positions. This is particularly true with handguns and can also be done with long guns. However, depending on the urgency and distance, the long-gun shooter may sometimes have the luxury of seeking additional support by bracing the elbows on the folded legs, particularly in the sitting and squatting positions. The latter can be so close to prone in stability that many Vietnam veterans who functioned in muddy environments that precluded the use of prone positions refer to it as *rice-paddy prone*. When it comes to prone positions, the angled ones that work well for target shooting may not be the best in a defensive setting. Remember that cover is often narrow; shooting both handguns and long guns from *straight-on* prone positions may not totally maximize marksmanship, but it may allow you to keep more of your body behind limited cover.

### EYE DOMINANCE

A problem that some shooters encounter when using sights is that the dominant eye may not be on the same side as the dominant hand. (Eye dominance is identified by extending your arm with the thumb up and covering the view of an object, such as a light switch, with the thumb. Close one eye—if the covered object is no longer covered, the eye that you closed is your dominant eye; if it remains covered, the eye that you didn't close is your dominant eye.)

With a handgun, the cross-dominant shooter may rotate the head to bring the dominant eye in line with the sights. With a long gun, the quick fix is to switch the gun to the other shoulder. For some shooters, this may actually be an easier way to shoot a long gun, particularly a pump-action shotgun, because the dominant hand assumes the task of supporting most of the weight of the gun and, if necessary, of working the slide.

## SKILLS

Barring a serious problem with one eye, the better solution in the long run is to learn to use either eye, according to which hand operates the gun. When you shoot around cover, this means that less of your head will be exposed. This presupposes that you will shoot right-handed around the right side of cover and left-handed around the left side of cover. Many instructors abandoned this concept in the belief that people won't shift the handgun to the other hand under stress. Perhaps, but when you use a long gun you really have to give up a lot of cover to shoot right-handed around the left side or vice versa. Also, you give up a lot of balance in the process.

My feeling is that training to shoot with the gun in either hand may pay off not only for better use of cover but also if the primary hand is wounded. Further, I find it very comforting to carry a gun accessible to each hand. When I had to draw on a robber while checking his knife hand, I would have been able to deal with him as effectively if I had had to use my dominant hand to check his knife hand as I did using my nondominant hand.

Getting back to training your eyes away from or into dominance, the trick is to use some frosted tape on the lens of your shooting glasses, over the eye that you don't want to use at the time. You start with a relatively large piece of tape and gradually reduce the size, making sure to place the tape over the portion of the lens that aligns with your pupil when you assume your shooting position. This system of successive approximation also works for the shooter who sees two different sets of sights while trying to aim the gun.

## AIMING THE GUN

Handguns are usually equipped with open sights: a notch in the rear and a post in the front. In most modern renditions the notch is square and the post is rectangular, at least when viewed from the rear. This allows the shooter to look *through* the notch at the front sight, aligning the top of the front sight with the top of the notch and leaving an equal amount of light on either side of the front sight. This is called

## DEFENSIVE USE OF FIREARMS

*sight alignment*, and it is essential for precision shooting. *Sight picture* is obtained when the aligned sights are visually superimposed on the intended target. In precision shooting the focus is on the front sight. The sights are not going to remain absolutely still while sighting. This leads many inexperienced shooters to *snatch the shot* when they think that they've got the perfect sight picture. Snatching the shot, however, usually results in a hit that's low and to the nongun-hand side, as the result of poor trigger control. Experienced shooters gradually increase the pressure on the trigger as the sights wobble and let the gun go off somewhat unexpectedly. In fact, at ranges back to about 7 yards, so long as the front sight appears somewhere inside the notch of the rear sight, shots can usually be kept within an 8-inch circle.

Most defensive handgun engagements occur at ranges and in time frames where there may only be the opportunity to get a very fast visual confirmation of the gun's body index on the threat. The late Jim Cirillo offered a method to accelerate this process by using only the silhouette of the handgun for aiming. To understand this method, aim your unloaded gun at something that can safely absorb a bullet and then shift your focus below the sights. On an autoloader you should be looking at the rectangular shape of the rear of the slide; on a revolver you should see the circular shape of the cylinder. If you slowly cock your wrist to one side, you'll begin to see the side of the slide or the cylinder. Come back to where you see only the rectangle or the circle and then slowly cock your wrist to the other side. Again, return the gun to its desired silhouette and then slowly cock your wrist upward until you begin to see the top of the slide or the upper surfaces of the cylinder. Return the gun to its proper silhouette alignment and then confirm its alignment by returning your focus to the sights—they should be quite close to alignment with your original aiming point. This *weapon silhouette point*, as Jim called it, may allow you to get a faster visual alignment, particularly in low light. To use it, simply place the silhouette of the gun over the area of the target you wish to hit. Revolver shooters may find it works better to place the silhouette of the cylinder on the lower edge of where you

## SKILLS

wish to hit. Some people actually shoot tighter groups this way, probably because they don't have a precise sight picture to tempt them to snatch the trigger. For most people who can use this technique, it's good out to 7 yards; some can use it out to 10 yards or beyond. In my experience, it seems to work better for my students with autoloaders than with revolvers.

Long-gun sights can take several forms. Some use open sights, similar to those on handguns. These are aligned the same way as handgun sights. Some are *aperture*, or *peep*, sights, where the rear sight is a round hole. With these sights the top of the post should be placed at the center of the circle. A variation on the aperture sight is the *ghost ring* sight. In this variation the hole is usually of a fairly large diameter, and the ring is thin enough as to be barely distinguished when the shooter looks through it.

Many shotguns are sighted by means of one or two beads. With a single-bead sight, the shooter's face must be low enough on the stock so that the sighting plane on the top of the receiver (and the rib, if present) is not visible. With a two-bead system the face must be low enough for the rear bead to obscure the front bead. One thing that seriously affects the accuracy of sighting with long guns is consistent placement of the face on the stock. This is true even if the long gun is equipped with a scope. What inexperienced shooters may not realize is that shifting their *cheek weld* back and forth on the stock affects the point of impact. While breathing is not usually a factor in defensive handgun shooting, the longer sight radius of long guns usually makes the rising and falling of the sights that accompany exhalation and inhalation more apparent. These things become significant when the long gun is used to obtain its intrinsic advantage of accuracy at longer ranges.

Students of marksmanship are usually advised to *call the shot*. This means noting where the sights are aligned at the moment the shot is fired. Like resetting the trigger, this is really just a training trick. Calling the shot forces the shooter to keep the eyes open at the moment the ears are assaulted with the sound of the discharge. Blink-

## DEFENSIVE USE OF FIREARMS

ing the eyes in anticipation of the noise is often associated with pushing the gun forward and downward in anticipation of its recoil.

### DRAWING THE CONCEALED HANDGUN

Handguns are low in power when compared to centerfire rifles or shotguns with serious loads. Their advantages lie in their greater portability and concealability. A handgun concealed anywhere other than on your person may be unavailable when you discover that you need it. To paraphrase Clint Smith, a handgun is a good weapon to use to fight your way to your long gun. If you have to retrieve your firearm from a place of off-body concealment, why not retrieve the more powerful long gun? The place for a defensive handgun is on your person, except when you aren't dressed fully enough to carry it. This means that you need to develop the ability to draw the handgun from your mode of carry.

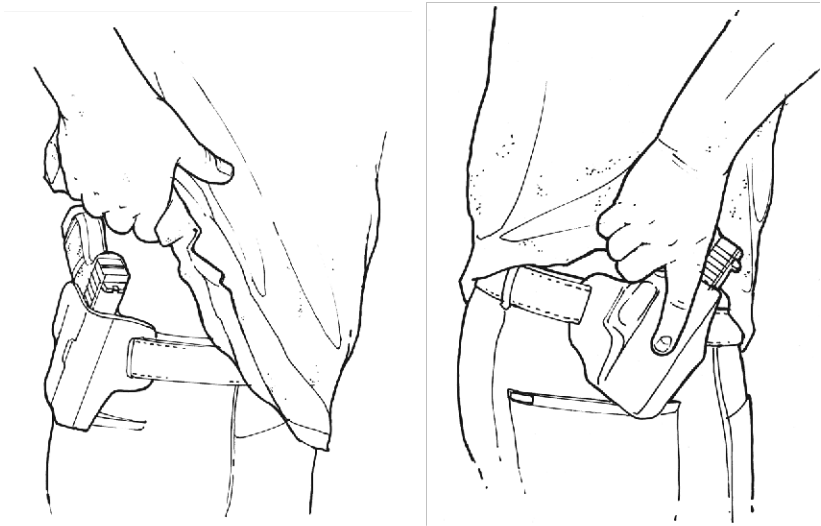

*A universal technique to clear the cover garment is simply to grab the hem in the vicinity of the holster and pull up. The actual draw is initiated by acquiring a firing grip on the gun while it is still in the holster. (Illustration by Jeff Cahill.)*

## SKILLS

Assume for the moment that you are using a belt holster on your gun-hand side. I teach the draw as a three-step process: (1) acquire the firing grip (or grasp) on the gun, (2) *lift, rock, and roll* the gun to the protected gun position, and (3) extend the gun to your aiming or more extended point-shooting position if conditions allow it.

If the gun is carried concealed, you'll need to clear the concealment garment. Most instructors teach different techniques for clearing a front-opening garment (e.g., an unbuttoned coat) and a pullover garment (e.g., an untucked golf shirt). Further, most instructors teach a two-handed technique known as the *Hackathorn rip* (named after Ken Hackathorn) for the latter type of garment. I teach a one-handed variation of the Hackathorn rip because you may not have two hands available to access your handgun in an emergency. I also favor *universal techniques* that will work under a wide variety of circumstances; the same technique that works for a pullover cover garment also works for an open-front garment. Simply grab the hem of the garment in the vicinity of the holster, pull up enough to clear the grip of the gun, and establish your grasp on the grip of the gun. (If you happen to be in an area with high wind, you may find that a wind at your back or gun side will counter the conventional technique for sweeping back one side of a front-opening garment in order to reach the holstered handgun.)

The grasp of the holstered handgun is initiated by placing the web of the hand as high as it can go for you on the back strap. Next, the middle finger wraps around the front strap, contacting the bottom of the trigger guard, and then the ring and little fingers curl around whatever is left of the gun's grip area. If there is no room for the little finger on the grip frame (or extension of the magazine), let it curl underneath it. The trigger finger should be positioned so that it will be on the frame, above the trigger guard, when the gun clears the holster.

The crucial part is that your hand must already be in its appropriate alignment relative to the bore at this point. If at all possible, the firing angle of the wrist should also be established while the gun is still in the holster. Some of us find the need to slightly rock or twist

## DEFENSIVE USE OF FIREARMS

the holstered gun from the initial position of the holster on the belt to accomplish this. The draw stroke is then initiated by *lifting* the gun high enough to clear the edge of the holster. At this point the muzzle is *rocked* forward, indexing it in the direction of the threat. The rocking motion, which is used to prevent swinging the gun forward of the torso, where it could become the target of a disarming attempt, is accomplished by *dropping* the elbow.

The protected-gun position is attained by placing the hypothenar eminence of the hand grasping the gun against the side of the rib cage; this is the *roll* part of the draw stroke. Optimally, this would be just to the side of the pectoral muscle or breast; some people have trouble raising the hand that high and may end up with the gun hand resting on the “love handle,” if there is one. By using that contact as an index, the gun is rotated outward about 20 to 30 degrees, as discussed previously, giving the slide of an autoloader the clearance to cycle, and pointing the muzzle at the midline of someone we face squarely, out to about 3 yards. In reality, the technique is reliable out to about two arm lengths.

As already mentioned, the challenge for people who may already be accustomed to drawing a handgun some other way is to rock the gun from the holster to the protected-gun position without swinging it past the body, where it could be grabbed by an assailant. The gun hand should track along the side of the body from the holster to the protected-gun position. If your handgun has a safety lever, disengage it as soon as the muzzle is indexed toward the threat. Because defensive uses of firearms often occur at gun-grabbing distances, it makes sense to condition yourself to go through this stage whenever you draw. From this position you can fire while sidestepping, blocking blows, deflecting or controlling knives, or countering any number of other challenges from targets that don't stand still.

This is a body-position-index technique. It depends, in part, on facing the threat squarely. Pivoting away from the line of attack swings your muzzle too wide; you need to train yourself to drag-step to the side. If you do have the space to extend the gun toward the threat, thrust

## SKILLS



*The next step in the draw is to rock and roll the gun to the protected-gun position. (Illustration by Jeff Cahill.)*



*If circumstances allow, complete the draw by thrusting the gun straight out to the position preferred for aimed fire. (Illustration by Jeff Cahill.)*

it—don't swing it—forward. Arcing the gun through the air, as we have all seen done in countless cowboy movies, is not only wasteful of time and motion, but it also can block your view of what is developing downrange. If you have the luxury of being able to shoot two-handed, bring the nongun hand in from the side, slightly below the line of the thrust, to meet the gun hand, at about the point where the elbows clear the rib cage.

You may not have the lux-

ury of shooting two-handed, and your brain may be so determined to focus on the threat that you may not even bring the gun up to the line of sight. However, you may have enough space that you need to get the gun in front of your body, which brings us to . . .

## DEFENSIVE USE OF FIREARMS

### THE POINT-SHOOTING CONTINUUM

In the period between World Wars I and II, two Englishmen serving in command positions with the Shanghai Municipal Police, W.E. Fairbairn and E.A. Sykes, produced a book entitled *Shooting to Live with the One-Hand Gun*. It is best known for its presentation of point shooting or, in the terms they used, hip shooting. It is important to note that their book was not based on theory but on their observation of 666 actual gunfights. Some of their observations may reflect the fact that the Chinese officers in that multinational department undoubtedly had extensive training in martial arts, but they primarily reflect their observation of the natural reaction of the human body to stress.

Earlier I mentioned the centerline concept from *wing chun kuen*. An easy way to visualize and check the application of this principle to shooting positions is to think of a vertical *knife edge* projecting forward of the body. If you place your palms together and rest your elbows against your rib cage, your fingers will show you the knife edge.

Fairbairn and Sykes described a *quarter-hip* (or *close-hip*), a *half-hip*, and a *three-quarter-hip* position, among which they saw their officers adjust, according to the proximity of the threat. In the latter two positions, the gun is held on the knife edge. The quarter-hip position, as they picture it, closely resembles what has been called the *speed rock* in more recent times and, in my

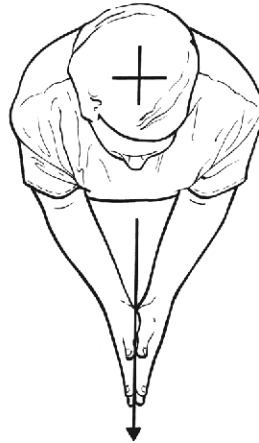

*Placing your palms together, with your elbows touching your rib cage, will allow you to visualize and check the “knife edge.” (Illustration by Paige Robbins.)*

## SKILLS

assessment, is not likely to produce effective hits because it fails to index the muzzle on the knife edge. I view the protected-gun position described above as an enhancement of their quarter-hip position because, even though the gun hand remains pressed to the side of the body, the supination of the forearm indexes the muzzle on the knife edge at distances of one or two arm lengths. Beyond that, the gun can be extended to the half- or quarter-hip positions, as appropriate, to keep it out of the grasp of the assailant.

One of the keys to the half-hip and three-quarter hip positions is to grasp the gun as though it weighs about 20 or 30 pounds; this will create a similar tension in the arm to that we create in the wrist, springing the gun back from recoil consistently. As with the wrist, you will find that there are positions of the arm where things just seem to click into place. Both techniques involve a natural crouch, such as how you might find yourself if you were



*The quarter-hip or close-hip position, as presented by Fairbairn and Sykes. The protected-gun position presented earlier is an improved version. (Reprinted with permission from Shooting to Live, published by Paladin Press.)*



*The half-hip position, as presented by Fairbairn and Sykes. (Reprinted with permission from Shooting to Live, published by Paladin Press.)*

## DEFENSIVE USE OF FIREARMS

walking down the street and heard a loud backfire from a passing truck. To learn the half-hip position, after you have assumed this natural crouch, hold the forearm horizontal to the ground with your gun hand slightly below the level of your solar plexus. As you clench the gun hand, to support a weight of at least 20 pounds, your upper arm will find its natural position in the vicinity of 110 degrees from the horizontal forearm. For the three-quarter-hip position, extend the arm to place the gun hand about the level of your sternum and again let Mother Nature establish the angle between upper arm and forearm as you assume the crush grip.

The illustration from *Shooting to Live* (available from Paladin Press) depicts the muzzle pointed well below horizontal because the shooter is depicted in the stalking mode. In the Fairbairn-Sykes sys-



*The three-quarter-hip position, as presented by Fairbairn and Sykes. Note that the shooter is depicted in the stalking mode, with the muzzle depressed. (Reprinted with permission from Shooting to Live, published by Paladin Press.)*

*As in the half-hip position, adjustments in elevation in the three-quarter-hip position are made by the tilt of the torso, not by altering the angle between the arm and the torso or between the upper arm and the forearm. (Illustration by Paige Robbins.)*

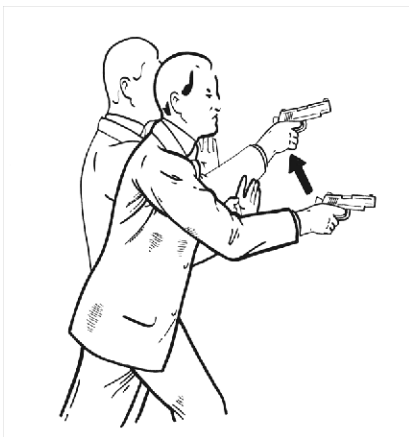

## SKILLS

tem, this is the primary technique, unless the distance to the threat dictates a more appropriate one.

The more recent illustration on previous page indicates that when one shoots from this position, elevation is not adjusted by sacrificing the locked position of the arm relative to the torso but by adjusting the tilt of the torso. Please note that Fairbairn and Sykes did *not* believe in what we now call Rule Three and actually trained their personnel to stalk with the finger inside the trigger guard. I strongly urge you to reject that aspect of their training and to keep the finger up on the frame until you are actually ready to fire the shot.

Most sudden threats will be addressed squarely, as already dis-

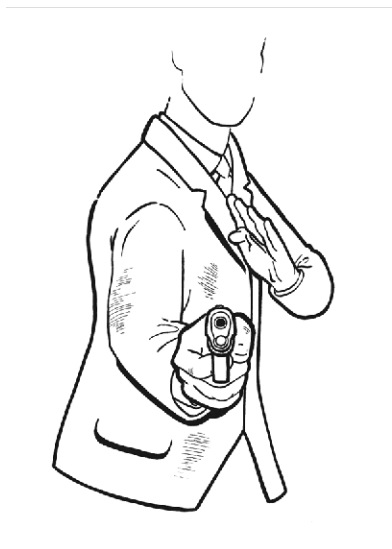

*If you are unable to pivot to address a threat on the side of the gun hand, the arm can be swung out to address it. (Illustration by Paige Robbins.)*

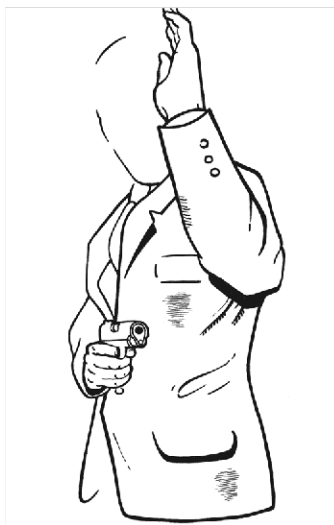

*If you are unable to pivot to address a threat on the side of the nongun hand, the forearm can be swung across the belly to address it. Note that raising the nongun arm to a blocking position raises it out of the line of fire. (Illustration by Paige Robbins.)*

## DEFENSIVE USE OF FIREARMS

cussed. However, there may be occasions where threats will appear from the side so quickly that you cannot pivot to address them or may not be able to because of the surface on which you are standing. In such cases, you can modify the half-hip position either by swinging the arm out to the gun-hand side or by swinging it onto the belly to address a threat on the nongun-hand side. In the latter case, it is crucial to make sure that the opposite arm is clear of the line of fire. This is easily accomplished by raising it to a blocking position.

Point shooting is not presented here because it is considered superior to sighted fire. It is presented because there is too much objective evidence that even shooters highly trained in two-handed sighted fire will fire one-handed, without looking at the sights, when confronted suddenly at close range. The sighted-fire techniques discussed earlier should flow naturally from these techniques when time and space allow their use.

### THE SAFETY CIRCLE

The untrained person drawing from a shoulder holster will likely cross his own nongun arm and describe a wide arc that may cross innocent parties and will likely swing past the intended target. Drawing safely from carry modes other than a dominant-



*The "safety circle" can be visualized as if you were standing in the center of a large tire. (Illustration by Jeff Cahill.)*

## SKILLS

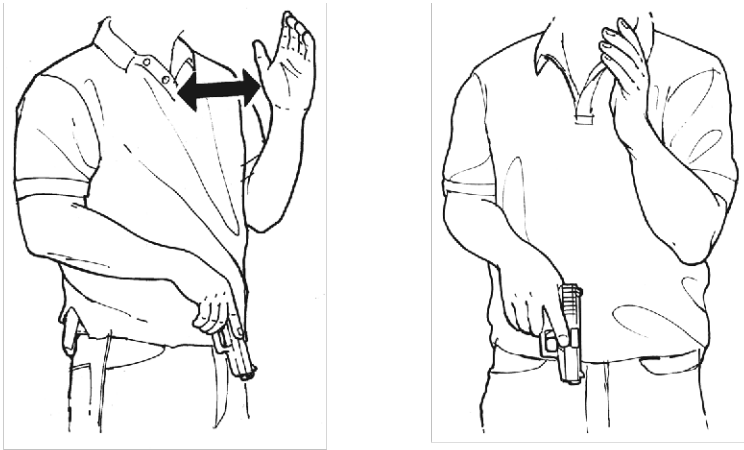

*The “navel position” is an adaptation of the safety-circle concept that allows you to move safely in any direction. The nongun hand is free to ward off blows, hold a flashlight, open doors, etc. (Illustration by Jeff Cahill.)*

side belt holster usually requires an understanding of the *safety circle*.

This concept assumes that the ground is a safe direction. This is true most of the time, but I do know of three separate incidents in which one person was critically injured and two were killed when shots were fired through upper floors of buildings into apartments or rooms below.

In any case, envision yourself standing in the open area of a large tire lying on the ground; the tire proper is your safety circle. When drawing the handgun from a shoulder holster, a cross-draw holster, or a fanny pack, index the muzzle on the safety circle as the gun clears the holster, and follow the circle until you can safely raise it to engage your selected target.

The same principle can be applied when you have to engage an additional threat you have detected at an angle that would require you to cross innocent parties if you simply swung the muzzle around, or if conditions preclude pivoting your stance for the initial draw. One example of this would be if you are seated. Further, this principle also allows you to move about safely with an unholstered handgun or an unslung long gun.

## DEFENSIVE USE OF FIREARMS

My preferred way to use the safety circle when moving with a handgun is what I call the *navel position*. To get there, simply start in the protected-gun position and slide the base of your gun hand along the body until your thumb is in front of your navel. This is one time when you actually want to relax the wrist, letting the muzzle point lower. The muzzle should point about 12 to 18 inches ahead of you, on the line that runs between your legs. This allows you to walk without crossing your own feet and legs and to safely approach within an arm's length of friendly parties. If you encounter a threat, you can either pull back to the protected-gun position if the distance is close or thrust the gun forward to your sighting plane if the distance is appropriate.

I teach holding the gun one-handed because it leaves the nongun hand free for performing defensive movements, opening doors, working a flashlight, or doing a great many other tasks that could arise. If the nongun hand is not yet committed, I recommend keeping it about 8 inches forward of the sternum. This allows you to make defensive movements to all four quadrants but, particularly for the right-handed person, to the upper left quadrant. Because most people are right-handed, a very high proportion of attacks with fists, knives, or impact weapons will be to that quadrant. A flashlight with an end-cap switch can be held in front of the sternum, but I now prefer to hold it on the nongun-hand side of my head. I also find that if I index the knuckles of that hand under the cheekbone, the beam points exactly where I swivel my head to look.

## CARRYING THE LONG GUN

Although you can carry a long gun on a sling when its use isn't imminent, it should be in your hands if you think you may need it in the near future. Assuming that you aren't engaging in prolonged patrol activity, the best course is to leave the toe of the butt in the shoulder pocket, with the muzzle pivoted downward to the safety circle. Depending on your flexibility and the degree to which you have to depress the muzzle, you may need to rotate the heel (upper corner) of

## SKILLS

the butt toward your sternum to keep the muzzle from crossing your feet as you move. People with broad shoulders or limited flexibility may even have to let the butt go forward of the sternum to get the muzzle pointed on the line that projects between their feet. You should check your long-gun safety-circle position in front of a mirror to ensure that the muzzle isn't pulled off to the side of your support arm, where it can cross your nondominant foot when you walk.

If you use a conventional sling to carry a long gun, there are a few modes of carry to consider. With a fairly short gun, such as an M1 carbine or some of the shorter AR-15 variants, I like to sling it muzzle down on the nongun-hand shoulder. This allows you to grasp the underside of the forearm with the support hand and swing the muzzle forward, letting the sling slide off the shoulder. The firing hand then reaches over to the small of the stock or the pistol grip, and the gun is rotated into the firing position.

With a longer gun, where there is a greater risk of sticking the muzzle into the ground if you squat, there are two schools of thought. Some people prefer to sling the gun muzzle up on the nongun-hand shoulder, on the theory that it allows the option of deploying the sidearm unhindered. This mode of carry allows you to “unsling” by hooking the nongun-hand thumb under the sling and permitting the muzzle to swing around to the front; the small of the stock or the pistol grip is grasped, and the muzzle is rotated down to the firing position. I prefer to sling a longer gun muzzle up on the gun-hand side, but I usually carry a handgun on each side of my body. In this mode, the gun is deployed by hooking the gun-hand thumb under the sling, raising the sling off the shoulder. The nongun hand then rises to grasp the gun near the *balance of the piece*, allowing the muzzle to rotate downward as the gun hand acquires its grasp on the gun.

None of these techniques gives perfect control of the muzzle—just one more reason not to wait until the last minute to deploy the gun from its slung position. A newer fashion is to use some sort of over-the-top sling that allows the long gun to hang in front of your chest if you need to release it for brief moments. Such slings may in-

## DEFENSIVE USE OF FIREARMS

hibit shifting the gun to the nondominant shoulder in the event that you have to fire around that side of cover. One answer to this problem is to use a *single-point* sling, attached where the stock meets the receiver, which allows the gun to hang in front of your body, with the freedom to mount on either shoulder. Such slings are not meant for long-term carry but to support the gun for very brief periods when one or both hands are otherwise occupied.

# 6 Equipment

---

*Beware of the man with only one gun.  
He probably knows how to use it.*

---

The point of this saying is not that you shouldn't select the best tool for the job; the point is that the skill of the operator is more crucial than the choice of equipment. In our nation's frontier days, the man who survived with only one gun was probably adept at using it in all settings. I rank choice of equipment as the lowest priority for personal safety and survival, but that doesn't mean that this choice is unimportant.

Some people will buy a firearm for self-defense but won't spend the money for a reliable one or one that they can operate reliably under adverse conditions. Others will spend the money on a good handgun but settle for a cheap holster that doesn't allow them to draw or reholster the gun efficiently. Some will buy a decent gun and holster but skimp on the belt that must support them. Then there are those who use full-power guns for recreation or home defense but rely on a small, low-power gun for carry outside the home, where ballistic power is more crucial because the attack is more likely to come at close range.

This chapter focuses on principles, not on attempts to convince you that what works well for me will necessarily work well for you.

## DEFENSIVE USE OF FIREARMS

### HANDGUN SELECTION

Firearms are launching platforms for their cartridges. Reliability of function is the primary criterion for selecting each of these. Ergonomics, the interaction between the user and the machine, is the next most important criterion in the selection of the firearm. If you can't reliably place hits on your selected target within a short time frame with a particular firearm, it's not the gun you want for self-defense. Handguns are particularly sensitive ergonomically. Major issues with handguns include whether the muzzle aligns readily with your intended target, whether you can work the trigger without seriously disturbing that alignment, and whether you can readily get the muzzle realigned with your intended target for follow-up shots. An additional consideration is the compromise among the power level of its cartridge, the ease with which you can control that power, and the size for concealment (if it's a gun you will carry). Not to be overlooked is the ease with which you can load, reload, and unload the gun.

Probably the first thing to establish in selecting a handgun is whether you shoot better single-action (where a light, short movement of the trigger fires a gun that is already cocked) or double-action (where a heavier, longer trigger movement first cocks the hammer or striker and then releases it, firing the gun). Most people can accomplish the light trigger press of a single-action gun more easily than the heavier roll of a double-action trigger. However, some people are more inclined to anticipate the shot, jerking it low, when firing single-action, so they may do better double-action. It has been argued that it is easier to discharge a single-action gun unintentionally, but a startle reaction is more than enough to fire a double-action gun if the finger has been placed inside the trigger guard prematurely.

Next is probably the choice between a revolver and an autoloader. The bullet exiting the bore of a single-action revolver will do just as much damage as if it comes out of a double-action revolver. However, most instructors don't advocate single-action revolvers for self-defense because the most common models take

## EQUIPMENT

longer to load and reload than their double-action cousins and may be slower for follow-up shots if you have only one hand free to work the gun. There are certainly skilled shooters of single-action revolvers who shoot them better than I shoot a double-action revolver, but unless you have developed this high level of skill and will carry a second one for your first reload, I recommend leaving these guns for the hunting fields and such venues as cowboy action shooting matches.

Double-action revolvers are relatively simple to operate—once you master the longer trigger stroke—because their cylinders swing out, allowing you to determine their loaded or unloaded status very easily. They can be easily disabled when not in use by simply placing a common padlock over the top strap when the cylinder is swung out. Their function is independent of the powder charge of the cartridge or of the shape of the bullet. A .357 Magnum revolver can fire anything from the lightest .38 Special target load to full-power .357 Magnum loads since the .38 Special is just a slightly shorter and lower-power version of the .357 Magnum cartridge.

A typical double-action revolver can still be thumb-cocked for a precision single-action shot, if desired. However, there are some revolvers with fully enclosed hammers, such as the Smith & Wesson Centennial series and the Taurus CIA series, that are strictly double-action. These guns can fire under almost any circumstances unless an assailant grabs the cylinder with enough force to keep it from rotating or wedges a finger behind the trigger. These guns are otherwise snagproof and will even fire reliably inside a pocket or with a garment draped over them. The S&W Bodyguard and Taurus Protector series guns split the difference, with a hammer shroud that lets the gun fire without snagging but still retains the option of thumb-cocking for the exceptional single-action defensive shot.

Unlike autoloaders, revolvers don't require a solid grasp or clearance for a recoiling slide in order to keep functioning. The smaller, five-shot versions with round butts are quite concealable. I routinely wear one behind each hip under an untucked golf shirt. Many people

## DEFENSIVE USE OF FIREARMS

carry lightweight versions as backup guns in pockets. I prefer to carry a slightly heavier steel-frame gun in the pocket for two reasons. If I need to use it, it will be under the worst of circumstances, when I may not have acquired a perfect grip. The added weight will serve both to dampen a bit more of the recoil and, more importantly, to stabilize the gun better against a hurried trigger pull.

Revolvers are slower and more difficult to reload than autoloaders, which carry their ammunition preloaded into magazines. Revolvers are very tricky to reload if you aren't in an upright position. Speedloaders, which carry cartridges lined up for the chambers of the cylinder, are designed to chamber a full cylinder load of cartridges at a time. They are relatively bulky to carry concealed. One alternative for .38/.357 revolvers is a device called a Speed Strip or a Quick Strip, which carries six rounds in a straight, flexible strip that allows chambering one or two cartridges at a time. Another option is a 2+2+2 pouch, which allows the user to grasp two rounds at a time—very useful if not every round in the cylinder requires replacement.

### PERSONALIZING THE GRIPS

Revolvers often benefit ergonomically by retrofitting the grip stocks to fit the hand of the user. The photograph at right shows three different approaches with S&W Centennial revolvers.



*Three different grip-stock options offer some choices to personalize the fit of a small-frame revolver without compromising concealment. (Photo by author.)*

## EQUIPMENT

Not many people shoot well with the rather skimpy factory grip stocks. The first-generation Model 40 still wears the factory stocks but with the addition of a Tyler T-Grip, which projects forward from the front strap, as well as favorably altering the angle of the trigger finger and the trigger. The grip safety, projecting from the back strap, slightly lengthens the reach to the trigger, which may benefit a large-handed shooter. The third-generation Model 640-1 is fitted with high-horn Boot Grips from Craig Spegel. Each half incorporates a slight palm swell, which fills an average-size male hand. Together with the high horn, these palm swells effectively distribute the recoil of .357 Magnum loads.

The second-generation Model 640, with Pachmayr Compac Professional grips, is better suited for a small-handed user, not only because of the smaller circumference of the grip but also because of its lack of a finger groove, which may not fit someone with thin fingers. Like the other two approaches, these grips also fill in some of the space behind the trigger guard. Only the Pachmayr Compac Professional extends slightly below the bottom of the grip frame. Some large-handed users are willing to give up some concealment by using grip stocks that extend past the back strap and below the grip frame of the revolver.

An additional factor to consider about grip stocks, whether for revolvers or autoloaders, is the degree to which they will or won't allow clothing to slide over them. While "soft rubber" stocks may feel fine in the hand, they may also prove too tacky to allow your cover garment to slide back down if it rides up while you twist and bend. This is even more likely to be the case if they are checkered. Further, checkering or tackiness may actually keep your hand from sliding to its optimal grip position.

Historically, autoloaders did not offer as much latitude in personalizing the grips, from an ergonomic standpoint, until very recently. However, several manufacturers of polymer-frame pistols now offer models with interchangeable "back straps" or "palm swells," permitting the user to select the one that best fits the hand. This feature is

## DEFENSIVE USE OF FIREARMS

normally found on the larger-capacity “service” pistols, which have relatively fat grip areas in the first place.

### AUTOLOADER CHOICES

Autoloaders are available in single-action, double-action, and double-action/single-action modes. The latter models are designed to be fired double-action for the first shot, leaving the hammer cocked for single-action follow-up shots. While this double-action/single-action combination can be mastered, it is a greater challenge than to master a gun that fires in the same mode for each shot. For the user who shoots better single-action, an autoloader is probably the way to go.

Autoloaders have a more complex manual of arms, requiring more training and ongoing practice for safe use. Many negligent discharges have occurred because the user has experienced brain fade and racked the slide prior to dropping the magazine while attempting to unload the gun—racking the slide with a loaded magazine in place simply loads the top round in the magazine into the chamber. Other negligent discharges have occurred when users thought that the gun had been unloaded simply because the magazine was removed. Some people feel that autoloaders “shoot softer” because some of the recoil is dissipated in the motion of the slide. Also, many autoloaders have lower bore axes than revolvers of comparable power and capacity, which reduces muzzle flip in recoil. On the other side of the coin, autoloaders are susceptible to malfunctions if they are not grasped firmly, if the trigger finger flies off the trigger the moment the shot is fired or if the shooting wrist is cocked to one side or another. They also won’t continue to function if something blocks the full travel of the slide.

Many autoloaders carry more rounds than most revolvers. This can be a mixed blessing because large-capacity guns tend to encourage a phenomenon dubbed *spray and pray*, putting out a large volume of poorly aimed fire. Spare single-column magazines generally conceal easily and comfortably; double-column magazines do not.

## EQUIPMENT

High-capacity autoloaders have fatter grip areas, which may inconvenience users with small hands, particularly if the gun has to be fired one-handed. Many high-capacity autoloaders were designed before the law restricting access to full-capacity magazines. (*Note:* The federal ban on “assault weapons” that restricted magazine capacity was allowed to expire by Congress in 2004, but at the time of this writing, state bans remain in California, Connecticut, Hawaii, Maryland, Massachusetts, New Jersey, and New York, and have been proposed in other states, including Illinois and Michigan.) Personally, I see little sense in buying a gun designed around 15-round magazines if you live in one of the jurisdictions that still restricts magazine capacity to 10 rounds. On the other hand, the difference between an 11- or 12-round restricted magazine and a private-citizen-legal 10-round magazine is minimal.

Some autoloaders are equipped with safety levers. If these are left engaged, they may delay someone who gets your gun away from you from getting off the first shot; if you do not practice diligently, they may delay you in getting off your first shot. The issue of manually operated safeties is of greater significance for people who have to carry their guns exposed, such as police officers or those who live in jurisdictions that only allow open carry.

Single-action autoloaders with exposed hammers have manual safeties. Double-action/single-action autoloaders have levers or similar controls to decock the hammer after a string of fire. On some it is a safety lever, which remains in the “safe” position until the user returns it to the “fire” position. Others have a decocking lever, which springs back to the “fire” position after the hammer has been decocked. Most double-action-only autoloaders do not have safety levers.

Many modern pistols lack a separate hammer to drive the firing pin and are said to be *striker-fired*. Some people feel that the terms “single-action” and “double-action” do not really apply to striker-fired pistols. However, some pistols, such as the Glock and Springfield XD, have trigger strokes that feel like those of single-action pistols while others, such as the Kahr, have trigger strokes that feel

## DEFENSIVE USE OF FIREARMS

like those of double-action-only pistols. Glock users who prefer the feel of a double-action-only trigger have the option of installing the *New York trigger* trigger-return spring, which will produce the equivalent of a very short double-action stroke. Safety levers are now appearing on some models of striker-fired pistols and are usually optional, as those on the Smith & Wesson M&P.

One thing that is easy to overlook is that many handguns with safety levers have them only on the left side, making the gun difficult to operate in the left hand. I place a high priority on having equipment I can operate with either hand. I am also a strong believer in carrying a gun accessible to each hand. It certainly makes no sense to carry a gun intended for use in the left hand that has a safety lever designed only for use in the right hand.

## AMMUNITION SELECTION

I generally recommend a minimum power level of .38 Special +P (higher pressure) in revolvers and 9x19mm (9mm Luger or Parabellum) in autoloading pistols. These rounds have the capacity to damage pelvic bone, even though they may not shatter it with a single shot. I consider this an important tactical option. An area of raging controversy nowadays is the debate over deep versus shallow penetration. I feel that private citizens are usually better served with conventional hollowpoint loads that are intended for relatively shallow penetration; this reduces the risk of shooting all the way through human targets. Private citizens are much less likely than police officers to have to shoot through barriers in self-defense.

As already mentioned, autoloaders are more demanding of ammunition selection for reliable function. They usually tolerate a narrower power range and may not always feed different bullet shapes or cartridge lengths reliably. The general rule of thumb is that, once an autoloader has been broken in, it should be able to fire 200 rounds of your chosen ammunition without a malfunction.

There are conflicting theories about how handgun rounds inca-

## EQUIPMENT

pacitate people. In fact, different rounds that have been pretty successful on the street seem to work by different mechanisms. In 9mm the best results have been with hollowpoints in the 115- to 127-grain weight range, preferably at the higher velocities offered by +P loadings. In .38 Special the best results have been in the 125- to 158-grain range, also at the higher velocities from +P loads. The gold standard for handgun ammunition has been the 125-grain, .357 Magnum semijacketed hollowpoint, with the slightly lighter and slower 110-grain loads as an alternative. At the other extreme, Federal's .45 ACP Hydra-Shok in the traditional 230-grain weight for that caliber seems to perform as well as the high-velocity 125-grain .357, even though it moves out about 600 feet per second slower. Most hollowpoints work well in this caliber. In the midcaliber .40 S&W, the 155-grain loads seem to split the difference between high velocity and increased bullet weight, with results approaching those of the best loads in other well-performing calibers, albeit at the expense of a very snappy recoil.

## HOLSTER SELECTION

A concealed-carry system includes at least one handgun, its holster, and, if it's a belt holster, a proper belt. A good holster not only secures the gun on your person but also positions it for an efficient draw and permits a one-handed reholstering without demanding that you remove your eyes from the threat area. The efficient draw requires that the grip area of the gun be accessible for a full firing grip to initiate the draw stroke. The ability to reholster one-handed depends in part on the holster's not collapsing when the gun is drawn and in part on the user's skill. Being able to get the gun back into the holster without taking your eyes off the threat can help lessen the chance of being shot by responding officers if you have shot an assailant or placed him at a position of disadvantage and are awaiting a police response. Being able to do so one-handed vastly reduces the likelihood of shooting yourself in the other hand while you are rehol-

## DEFENSIVE USE OF FIREARMS

stering. A belt holster usually meets both these requirements better than any other type.

If you make a fist but leave your index finger extended and, while standing, place it at your waist, just above your hip joint, you will find that your finger points straight down. If you now start moving your fist to the rear, you will find that the finger starts pointing increasingly to the rear. Similarly, if you move the fist forward of the hip joint, the finger will point increasingly forward. This should suggest that the angle or rake of the holster should be selected for where on the belt you plan to position the holster.

One other factor that determines how well the holster suits you is how high or low it rides on the belt. Women usually have more flared hips and shorter trunks than men. While a man will usually do fairly well with an FBI-style holster that positions the gun behind the hip joint with the muzzle angled somewhat to the rear, most women will find that the rear of the gun sticks into their ribs or their armpits with such a rig. Women are generally most comfortable with a concealment holster in the appendix or front cross-draw position (respectively, the gun-hand and nongun-hand sides of the navel). This usually requires holsters with varying degrees of forward rake. Whereas the FBI rig places the gun in the area where physically fit males usually have something of a hollow, the forward placement favored by many women places the gun where it will be concealed in the drape of an untucked shirt or blouse.

The next major issue in belt holsters is whether they are worn inside or outside the waistband of the pants or skirt. Inside-the-waistband (IWB) holsters offer several advantages for those who are comfortable wearing them. Since most of the holster and the handgun are covered by the pants (or skirt) in this mode of carry, the shirt, vest, or jacket used to cover the gun doesn't need to come as low. Because the belt rides outboard of the holstered gun, the gun will be pressed more tightly into the body for better concealment; the belt also need not be as wide or as stiff as would be required to stabilize a holster worn outside the waistband. Additionally, if the holstered gun is worn

## EQUIPMENT

inside the pants, it will not block access to the pockets. IWB holsters, however, require the pants or skirt to have a larger waistband and a correspondingly larger belt. Some people with a little extra padding may pinch that tissue with the muzzle of the gun when sitting with an IWB holster, although this can be minimized with one of the designs that incorporate a flange around the sides and bottom of the holster.

Other types of holsters include the following:

- *Shoulder:* Shoulder holsters essentially require a cross-draw, which can be blocked by an assailant who is close enough to trap your arm against your chest. If you aren't trained to use the safety circle concept, such a draw will likely cross your own nongun-hand arm and possibly innocent bystanders; it may also overswing your intended target. If you are trained to use the safety circle, it will give you a safer but slower draw. A vertical shoulder holster may be useful in weather that requires an overcoat, so long as you leave the top button or two undone. A shoulder holster may be a useful option for someone who spends a lot of time seated while wearing some sort of coat.
- *Ankle:* Ankle holsters aren't a good place for a primary gun if you spend any time on your feet, but they may be good for a backup gun. An ankle holster is more easily accessed if you're seated or if you've been knocked on your back and have rolled with your knees flexed toward your chest. Ankle holsters require wide pants cuffs and may cause nerve-based pain (paresthesia) in the legs of some users. Most users of ankle holsters place them on the inside of the nongun-hand leg, for draw with the primary gun hand. Many users of ankle holsters favor relatively light-weight guns, such as revolvers with aluminum-alloy frames or autoloaders with polymer frames, for this role.
- *Pocket:* Pocket holsters are usually thought of in terms of backup guns but, with the right combination of gun, holster, and clothing,

## DEFENSIVE USE OF FIREARMS

may serve for a primary gun for the user who must be very discreet. One of the crucial challenges for a pocket holster is allowing acquisition of a full firing grip while the gun is still in the pocket; this may require the services of a tailor. A man can usually stand around with his left hand in his front pants pocket without attracting undue attention. On the other hand, a front pants pocket is not conducive to an easy draw while seated. It is important to realize that different holsters will probably be needed for pants-pocket carry and coat-pocket carry since the pockets are usually shaped differently. Coat-pocket carry is a useful option in cold weather. Pocket carry may demand a lightweight gun to avoid obvious sagging of the garment. Personally, I favor Smith & Wesson's older aluminum-alloy-framed Airweight Centennials for this role if weight reduction is essential. The newer and lighter titanium-framed versions may have trouble with bullets being pulled from their crimps by the excessive recoil. Further, Smith & Wesson has cautioned against using .357 rounds with bullet weights under 120 grains in its revolvers with titanium cylinders because of concerns about erosion of the titanium with the faster-burning powders used with the lighter bullets.

- *Fanny pack:* Anyone with knowledge of concealed carry assumes that any fanny pack of decent size carries a handgun, negating one of the advantages of concealment. Some of these contraptions may also require two hands to draw, a luxury that you may not have in an emergency. Draw from a fanny pack holster also requires use of the safety circle.
- *Deep cover:* There are various deep-cover systems (e.g., Pager Pal, Thunderwear) that seek to offer very discreet carry by placing the grip of the handgun below the waistband. These provide effective concealment to some users and obvious bulges to others. They usually require a two-handed draw, making me very uncomfortable with the concept. On the other hand, if they work for

## EQUIPMENT

you, it probably beats leaving the gun at home if you can't carry in a system that allows you to draw one-handed.

- *Off-body carry*: Women's purses are notorious for poor organization, making them a poor place to toss an unholstered handgun. Some purses are specifically built with holsters for handguns. One brand even includes a stainless-steel cable in the shoulder strap as protection against thieves who slash shoulder straps with razors. This would seem to offer a counter to my argument that a purse is the most likely target of a man who attacks a woman on the street, making purses containing handguns a good means to arm muggers. Consider another scenario: a person in a moving vehicle who grabs the cable-reinforced purse strap in the expectation that it will break. I know of one woman who was dragged to her death in such a purse snatching. The bodyguard for former Secretary of Housing and Urban Development Andrew Cuomo used to carry his revolver in a zipper bag labeled "Department of State Security Services." It is alleged that there were at least a half dozen instances of the revolver's being returned to the bodyguard by several police departments after he laid the bag down and forgot it. Off-body carry is a violation of Rule Five!

## SPARE AMMUNITION

My first choice for a carrier of spare ammunition is a second gun. While I usually carry an extra five rounds in this manner, I also carry six more revolver rounds in a pouch on my belt. My choice for this is a 2+2+2 pouch, which, when unsnapped, tilts away from the belt and presents the cartridges in pairs.

Some people prefer to carry revolver rounds in Speed Strips or Quick Strips, and there are a few pouches made specifically for those. Others may opt for a small set of belt loops. Speedloaders usually provide a faster reload of the entire contents of a revolver's cylinder. However, they are bulky to conceal. When carried on the

## DEFENSIVE USE OF FIREARMS

belt, speedloaders are best concealed in a carrier that places two or three of the rounds between the pants and the belt and the remaining two or three outside the belt; the barrel of the speedloader straddles the belt in this arrangement. Spare ammunition for revolvers is usually best carried on the gun-hand side of the body because the complex task of getting the new rounds into the chambers is more easily accomplished with the dominant hand.

Spare ammunition for autoloaders is usually carried in spare magazines on the belt, on the nongun-hand side, for those concerned with concealment. Single-column magazines usually ride comfortably in IWB pouches, for those who prefer that mode. Alternatively, a conventional leather double-magazine pouch can be worn “inside out,” between the belt and the pants. Staggered-column magazines are usually uncomfortable to wear in IWB pouches.

Some users of high-capacity autoloaders do not bother with spare magazines because they feel that the contents of one magazine should suffice for a self-defense incident. However, since malfunction clearance may involve a magazine change, it is wise to have at least one spare available.

While I am uncomfortable with paddle holsters (where the holster is mounted to a paddle that rides inside the pants while the holster rides outside), I don't object to this mode for an outside-the-waistband magazine pouch. If someone grabs my handgun and rips the paddle holster out of my pants, he's got my gun. If someone grabs my spare magazines, he can't shoot me with them.

## NIGHT SIGHTS AND LASERS

Like most things in the world of firearms, self-illuminating tritium night sights have their proponents and their opponents. The most compelling argument against them is that they may reveal your position to someone who is stalking you from behind or, if you wear eyeglasses, possibly even to someone to the front, should they reflect in the lenses. Nevertheless, most of my own serious handguns have

## EQUIPMENT

them, if only in a “big-dot” front sight, and so do some of my serious long guns.

I own only one handgun equipped with a laser sight, and that is only for teaching purposes. Although there may be exceptional circumstances for particular users, I am concerned about laser sights discouraging people from developing or maintaining the skill of using the conventional sights on the gun. If you can only shoot with a laser dot on the target, you will have a lot of trouble the night that your battery goes dead.

## FLASHLIGHTS

Whatever your decision on night sights and lasers, you must understand that they can only help verify the alignment of the gun with the target—they do nothing to help you verify the identity of the target. For that reason you really should be carrying a minimum of one flashlight. Since flashlights use batteries, it makes a lot of sense to carry at least one backup.

Personally, I carry two dual-mode flashlights that offer high-intensity white light or low-intensity red light from light-emitting diodes (LEDs). The high-intensity light not only gives me optimal illumination in those moments when I may have to make the decision whether or not to shoot, it may also disorient an assailant enough to eliminate the need to shoot. On the other hand, when I just have to see something in the dark, I prefer to use the red light to reduce the loss of my own night vision. The entire world of flashlights is still in flux due to development of high-intensity LED lights, which give much longer battery life and generate much less heat. The SureFire Aviator A2 I have just described is now available in an all-LED model.

Some holster makers offer pouches that pair up one spare magazine with a SureFire high-intensity flashlight. SureFire offers its Executive series lights with pocket clips. A variety of LED lights are available in key ring models. SureFire offers its A2 Aviator, as described above, which combines three red LEDs with a high-intensity

## DEFENSIVE USE OF FIREARMS

halogen bulb, all in one unit with a two-stage switch, giving the operator a choice of color and level of illumination.

There are small flashlights that are the size of pens and can be clipped in shirt pockets in a similar manner. There are also numerous LED lights designed to be carried on key rings. I use one that offers three levels of intensity and also includes a strobe function, for use as a distress signal; I wear it on a necklace, with some other survival gear. Some of the larger LED “tactical” lights incorporate a strobe function because a bright strobe is thought to be more disorienting when shined in the face of an assailant; it may also be a bit disorienting to the operator. Some of these larger lights are equipped with clips, permitting carry in a pants pocket. Numerous belt pouches are also available for flashlights of this size, including some which carry a spare magazine and a similar-size flashlight side by side.

## OTHER EQUIPMENT

Another non-firearm item that is really essential is a cellular telephone. Just think of how much police officers rely on their radios. If you are ever forced to draw on an assailant and he runs off, you really need to be the one who dials 911 first. The assailant may not want to risk being picked up for attempted robbery, and if he’s the one who calls in first with a complaint about a wacko threatening him with a gun, you will likely be trying to talk your way out of a charge of aggravated assault (or whatever it’s called in your jurisdiction). Inexpensive Bluetooth accessories for your cellular phone allow hands-free operation, a very useful option if you must talk on the phone while you’ve still got a gun in your hand.

Some people also carry intermediate-force devices such as “pepper” spray. This is not a bad idea if you have the space in which to carry it; I don’t have the space on my waist or in my pockets. Such defensive sprays give you something other than your own body parts if you must deal with a threat that does not rise to the level of deadly force.

## EQUIPMENT

### LONG GUN SELECTION

As already stated, handguns are good tools to fight your way to your long gun. Handguns are relatively weak ballistically but are often small enough to be carried discreetly on the person. Handguns are carried in case danger comes to you unexpectedly; long guns are what you want when you know that you're going to have to deal with a dangerous threat. Most of us cannot carry them around on a regular basis. Nonetheless, we can keep them in our homes and, in some jurisdictions, can carry them in our vehicles.

I'm convinced that the reason the shotgun has served so long as the traditional long gun in U.S. law enforcement is that it is usually cheaper than a rifle. Shotgun fans argue that the antipersonnel shotgun delivers a tremendous amount of damage to its target. They usually express this in terms of a load of buckshot. The traditional police "double ought" 12-gauge load launches nine .33-caliber, 54-grain lead balls or pellets. Out of a typical 18- to 20-inch barrel, such a load will stay together for about 1 yard and then spread approximately 1 inch per additional yard of travel. While many instructors state that such a combination is appropriate out to about 15 yards, they base this on shooting standard stationary silhouette targets, pointing out that all the pellets remain on the silhouette at that range. Real people, however, diminish in thickness toward their edges and rarely remain stationary while posing deadly threats; they may also pose the threat while turned sideways. Absent special loads coupled with modified barrels, buckshot-loaded shotguns probably shouldn't be used much beyond 7 yards.

While I do not rely on my 12-gauge shotgun as my primary home-defense long gun, my own choice of a defensive buckshot load in that gun is the standard-velocity #1—which launches sixteen .30-caliber, 40-grain pellets. I'm gambling that this load will give adequate penetration to do its intended job while minimizing the risk of exiting the body of someone who may threaten me from across a room.

## DEFENSIVE USE OF FIREARMS

Some people advocate the use of birdshot loads for home defense. These pellets are much smaller, but there are a great many more of them in each shell. At distances of 1 to 2 yards they are devastating but may not reliably incapacitate an assailant across the room.

Shotguns can also launch slugs. The traditional slug is the Forster “rifled” slug, a hollow lead “can” that weighs 1 ounce in most 12-gauge loadings. Most experienced users can hit reliably with these out to 50 yards. They are high-penetrating loads, capable of shooting into automobiles. They are also likely to exit human targets at closer ranges unless they strike large bones. Newer slug designs—such as the smaller-diameter, pointed sabot slugs that ride down the barrel in split plastic sleeves—have even higher penetration, making them unsuitable for defensive use.

The cost of the power of the 12-gauge shotgun is recoil. Although good technique makes the recoil manageable, an alternative for those who want to use the shotgun is the 20 gauge. The only commercial buckshot load in the standard 2 3/4-inch, 20-gauge shell is #3, which typically launches twenty .25-caliber, 23-grain pellets. Compared to the 12-gauge, #4 buckshot load used by some law enforcement agencies, which launches twenty-seven .24-caliber, 21-grain pellets, the 20-gauge load has less recoil and will get you back on target faster if follow-up shots are required.

Magnum shotshells aren’t desirable for defensive use because, in addition to greater recoil, they also produce wider spread. On the other end of the buckshot load spectrum are the 12-gauge tactical loads marketed to law enforcement agencies (but often found for sale at gun shows or over the Internet). These are lower-velocity loads with lower recoil and less pellet spread. Some of the 00 loads contain only eight pellets instead of nine, and the pellets are usually hardened and plated to reduce deformation, further reducing spread. By this time it should be obvious that, myths to the contrary, shotguns do require aiming to hit what you need to hit and to avoid hitting anything else.

An extensive variety of long guns with rifled barrels exist. To varying degrees some of these are suitable for defensive use. Loads

## EQUIPMENT

from big-game rifles are often too high-penetrating for self-defense. At the other end of the spectrum of rifled-barrel long guns are the pistol-caliber carbines. Most of these are semiautomatic guns that fire cartridges normally intended for autoloading pistols. The advantage of these guns is likely to be greater hit potential than with a comparable handgun, owing to the extra point of support at the shoulder.

Most autoloading-pistol loads won't gain that much more velocity from the longer barrel. However, if other circumstances (e.g., legal restrictions) rule out a semiautomatic carbine, a lever-action carbine chambered for one of the Magnum revolver cartridges delivers a significant increase in velocity and energy. The .357 Magnum out of such a carbine delivers a serious punch with relatively low recoil, making it suitable for family members who may not be firearms enthusiasts. At a similar ballistic level is the venerable M1 Carbine, classified as a "Curio and Relic" in its original military version, and available newly manufactured from such outfits as Auto-Ordnance. For years there were two rounds available for the M1 Carbine that were suitable for defensive use: Winchester's "hollow softpoint" and Remington's softpoint. Since the initial publication of this book, Cor-Bon has introduced a DPX load with an all-copper hollowpoint bullet, attractive for those who think they may have to shoot through some sort of light cover. Speer has also introduced a softpoint bullet in its Gold Dot line.

While many other military loadings are likely to overpenetrate, the earlier .223 loads with bullets in the 55-grain range are not likely to go through and through, even with fully jacketed bullets. In fact, in at least two law enforcement tests, .223 rounds were shown to be less likely to penetrate common building materials than pistol rounds fired from carbines or submachine guns. Carbines are available in this caliber in several variations of the AR-15, Ruger's Mini-14, various military lookalikes formerly imported from other nations, and even bolt-action rifles of several persuasions.

Note that the more recent versions of AR-15s and some other military-style rifles and carbines in .223 tend to imitate the military

## DEFENSIVE USE OF FIREARMS

trend to the fast barrel twist rates required to stabilize the heavier bullets used more recently by the military for longer-range accuracy and better penetration of body armor. Such 1-in-7-inch twist rates are not optimal for personal defense and, if used, should definitely be limited to softpoint or hollowpoint loadings.

When using rifles in other calibers for self-defense in environments where innocent bystanders may be out of sight downrange, softpoint or hollowpoint bullets should likewise be used. Although softpoint bullets usually won't expand adequately at pistol velocities, they are likely to do so at rifle velocities. If you are using a caliber intended for hunting, the lighter bullet weights are less likely to over-penetrate. If you are choosing among loads intended for hunting, most likely you will want to select the ones marketed for varmints or smaller, thin-skinned game. In .30-30, for example, Winchester offers a 150-grain conventional "Super-X" jacketed hollowpoint that is less penetrating than its Silvertip load in the same bullet weight. Federal offers a 125-grain jacketed hollowpoint in this caliber that also has the limited penetration appropriate for defensive use.

# 7 Legal Issues

---

*Self-defence is Nature's eldest law.*  
—John Dryden, “Absalom and Ahithophel”

---

I am not an attorney, hence I am not licensed or qualified to give specific legal advice. I can, however, assure you that today’s legal environment in the United States is much more complex than Dryden’s declaration about Nature’s eldest law. I can also share some general concepts that should serve as a starting point for your research about the particulars in those jurisdictions where you live and are likely to travel.

In all U.S. jurisdictions you have a right to self-defense, so long as you haven’t provoked the confrontation. This means that if you choose to arm yourself, you are expected to take particular care to avoid conflict that may result in the use of force. (There is considerable variation in the law from state to state, particularly in terms of whether you have the right to stand your ground or whether you have a duty to retreat before resorting to force.)

You generally aren’t allowed to use a greater level of force than that force which threatens you. Thus, if someone punches or convincingly threatens to punch you, you will not be justified in shooting him unless you can convincingly argue that, in your exceptional case, the punch would have placed you at risk of death or permanent injury. This brings us to a concept I have borrowed from Massad Ayoob, who has summarized what I call the golden rule of the use of deadly force in self-defense:

## DEFENSIVE USE OF FIREARMS

*You may use deadly force only in the event of an immediate, otherwise unavoidable threat of death or grave bodily harm to yourself or other innocent human life.*

Deadly force is force that a reasonable person, knowing what he knows at the time, could expect to kill or produce crippling injury. Different states may have specific definitions, particularly of “grave bodily harm,” “great bodily injury,” “serious bodily injury,” etc.

If someone says, “I’ll be back to shoot you as soon as I get my gun,” the threat is not immediate.

If someone says, “I’ll smack you in the head with this baseball bat if you don’t get out of here,” the threat is otherwise avoidable.

If you are the victim of an unprovoked attack, your innocence will be certain to you, even if it may be difficult to prove to police, prosecutors, or a jury down the line. Coming to the aid of a third party gets trickier, particularly if you weren’t there for the start of the incident. Things aren’t always what they seem, and bullets lack brakes and steering wheels. Further, the concept of defending other innocent parties is limited to human life—the courts won’t look kindly on your killing another human being to protect an animal.

Your threat to use deadly force may not only justify the other party’s use of similar force against you, it will also require very similar justification to that required for the actual use of force. In most jurisdictions, an unjustified threat of deadly force is called “aggravated assault.” Thus you likely can’t expose or draw a concealed firearm (or place your hand on an exposed one) until you believe that you are the object of a deadly threat.

Your perception of a deadly threat must be reasonable, incorporating the knowledge that you have at the time.

The assailant must possess the ability to kill or maim. This need not be a gun, knife, club, or other improvised weapon. If the assailant is much larger or stronger than you, is known to possess special skills in martial arts or prizefighting, is a man threatening a woman, or is a

## LEGAL ISSUES

member of a group that makes the threat, you may be able to argue that the disparity of force would have made the attack deadly.

The assailant must have the opportunity to employ the ability. A man with a knife who is on the other side of a 12-foot chain-link fence doesn't have the opportunity to kill or maim you with the knife. On the other hand, he does have the ability to kill or maim you with a firearm from the other side of that same fence.

Ability and opportunity do not complete the reasonable apprehension of a deadly threat. The assailant must also be acting in a manner that leads you to conclude that you are being placed in jeopardy. A man, an arm's length away from you, testing the edge of a bowie knife on display at a gun or knife show has ability and opportunity but is not likely placing you in jeopardy. This concept is a tripod: if one leg is not present, the whole thing collapses.

By this point it should be obvious that, as stated previously, the firearm covers only a narrow band in a much wider spectrum of self-defense. Further, even the use of lower-level physical force—such as “pepper” spray, grappling holds, or punches and other strikes—must be justified in a similar manner. It is crucial to realize that mere words from the other party, no matter how severe, are never, by themselves, justification for the use of force. The words, however, coupled with overt actions, may contribute to your perception of jeopardy.

Law has two major branches: criminal and civil. Criminal law relates to acts that are considered offenses against society, for which you can be fined, jailed, or put to death. Civil law relates to acts that are considered offenses to individuals, who may sue you for redress. Your loss in a civil suit will generally result in a monetary judgment against you. Your use of force can easily result in both criminal prosecution and civil suit.

Most of your rights against self-incrimination, unreasonable search and seizure, double jeopardy, innocence until proven guilty beyond a reasonable doubt, etc., have been expressed in terms of criminal cases. You have fewer rights as a defendant in a civil case. Thus, if you carry a gun, you should also carry the phone number of

## DEFENSIVE USE OF FIREARMS

one or more attorneys who are available to you 24 hours a day. If you are questioned by police, particularly under the emotional overload of having been forced to shoot someone, you aren't going to be thinking clearly. Even if the police perceive that you acted reasonably in self-defense, the officers won't be trained to protect your rights in a possible civil action. Avoid telling the police anything other than that you were a victim of a threat on your life and pointing out possible witnesses and evidence at the scene. It's better to spend some hours in jail waiting for your attorney than to spend several years there and to lose your life's savings, the kids' college funds, etc., because you didn't await that counsel.

# Glossary

---

- .25 auto:** An autoloading handgun that fires the very low-power .25 ACP cartridge.
- .357 Magnum:** A powerful revolver cartridge that uses a bullet with a diameter of 0.357 inch; a longer version of the .38 Special cartridge.
- .38 Special:** For much of the 20th century, the predominant revolver cartridge used by U.S. police officers; see .357 Magnum.
- .40 S&W:** A cartridge for autoloading pistols that uses a bullet with a diameter of 0.40 inch; it has become the predominant cartridge in law enforcement in many areas.
- .45 ACP:** The cartridge originally designed for the .45-caliber Automatic Colt Pistol used by the U.S. Army for most of the 20th century; it uses a bullet with a diameter of 0.451 inch.
- 9mm:** A cartridge for autoloading pistols that uses a bullet with a diameter of 0.355 inch; there are several 9mm cartridges, but in this book the term is used to refer to the 9mm Luger or 9mm Parabellum cartridge.
- +P:** A designation for a cartridge loaded to produce higher pressures when fired than the original specifications for the cartridge in question; those higher pressures are intended to produce higher bullet velocities.

## DEFENSIVE USE OF FIREARMS

- action:** The frame of the firearm together with the mechanism for chambering and firing the cartridges.
- autoloader:** A firearm that automatically ejects the empty cartridge case and loads a new cartridge into the chamber when each shot is fired; this method of operation is also called “semiautomatic,” as distinguished from a fully automatic firearm, which keeps firing as long as the trigger is kept pressed to the rear, and ammunition remains.
- Ayoob, Massad:** A firearms journalist and instructor who operated Lethal Force Institute and now teaches under the name Massad Ayoob Group.
- back strap:** The rearmost portion of the frame, where a handgun is grasped by its user in firing.
- ballistic vest:** Generally the “soft” body armor worn by police officers under a shirt; such “vests” are bullet resistant, not truly bulletproof.
- birdshot:** Small, spherical lead pellets that are fired, a great many at a time, out of shotguns; usually used to hunt small, moving game.
- bore:** The “hole” in the barrel of a firearm through which the bullet or shot is launched.
- buckshot:** Relatively large, spherical lead pellets fired out of shotguns, several at a time, to hunt game as large as deer and for antipersonnel use.
- bullet:** A single projectile designed to be launched from a “rifled” barrel of a firearm; “rifling” is a set of spiral or helical grooves that impart a spin to the bullet.
- cartridge:** A “package” consisting of a case, a primer, powder, and a bullet; for a shotgun it is referred to as a “shell” and contains shot or a slug instead of a bullet.

## GLOSSARY

- catastrophic failure:** A firearm malfunction in which something “blows up,” usually the cartridge case, with possible damage to the firearm and the shooter.
- centerfire:** A cartridge whose case has a separate primer inserted centrally; its more robust construction allows it to be loaded to higher pressure than a rimfire cartridge.
- chamber:** More correctly, “firing chamber,” this is the portion of a firearm that supports the cartridge as it is fired; it is often the rearmost portion of the barrel, but revolvers have several chambers bored through a rotating cylinder.
- Chapman, Ray:** Now deceased, Chapman established the Chapman Academy of Practical Shooting after winning the first world championship in that sport.
- Chapman Academy:** The now-defunct shooting school founded by Ray Chapman (see above).
- chemoluminescence:** A chemical reaction that gives off light, used in making “light sticks.”
- Cirillo, Jim:** Now deceased, Cirillo was probably the most “prolific” U.S. law enforcement gunfighter of the second half of the 20th century; he gained fame while serving on the New York Police Department Stakeout Unit and wrapped up his law enforcement career as a firearms instructor at the Federal Law Enforcement Training Center (FLETC).
- Cooper, Jeff:** Now deceased, Cooper was a retired U.S. Marine Corps officer who established a school now known as Gunsite Academy; his modern technique of the pistol was the predominant style taught in law enforcement for many years.
- cross-draw:** The draw of a handgun carried on the nongun-hand side of the body; also used to describe a holster intended for carrying on the opposite side from the gun hand.
- cylinder:** The cylindrical, rotating portion of a revolver that contains the firing chambers that successively align with the barrel when the revolver is fired.

## DEFENSIVE USE OF FIREARMS

**double-action:** In today's parlance, a trigger system that first cocks and then fires a firearm, with a relatively long stroke of the trigger; could also be called "trigger-cocking."

**dry-fire:** A training method for shooting in which the shooter fires an unloaded firearm; essential for developing good trigger control.

**dummy round:** An inactive cartridge assembled without powder or primer, used to practice reloading and malfunction clearance, and by gunsmiths checking firearm actions.

**Fairbairn, William Ewart:** Co-author of *Shooting to Live*, Fairbairn ended up in the United States during WWII, training operatives for the OSS, predecessor to the CIA.

**forcing cone:** The rearmost portion of a firearm barrel bore, which is tapered to ease the transition of the projectile from the chamber into the narrower bore of the barrel.

**grain:** A unit of weight equivalent to 64.8 mg; there are 7,000 grains in an avoirdupois (common) pound.

**grip frame:** The portion of a handgun gripped or grasped by the shooter; in most modern autoloading pistols it contains a cavity for the magazine.

**Gunsite:** The shooting school founded and formerly operated by Jeff Cooper (see above).

**Hackathorn, Ken:** A firearms instructor who teaches a great deal more than his two-handed technique for drawing a handgun concealed under a pullover garment.

**handgun:** A firearm designed to be shot in one or both hands, with no stock for support at the shoulder.

**high-power rifle:** A rifle designed to fire a centerfire cartridge, as opposed to one of the common-variety .22 rimfire cartridges, which are much lower in velocity and power.

## GLOSSARY

**hollowpoint:** A bullet with a hollow cavity in the nose, generally to facilitate expansion when it strikes flesh.

**Jordan, Bill:** Now deceased, Jordan served in the U.S. Border Patrol when its agents got into more gunfights than any other officers in the United States; he was a phenomenal shooter who could consistently hit aspirin tablets without using the sights on his revolvers.

**long gun:** A term that applies to both rifles and shotguns because of the presence of both a stock for support at the shoulder and a longer barrel than on a handgun.

**magazine:** A boxlike container for firearm cartridges equipped with a spring system to feed the cartridges into the “action” of the firearm; most defensive firearms use detachable magazines, sometime erroneously referred to as “clips.”

**manual of arms:** Originally a military term for the manipulation of a firearm in drill, the term may also be used for the procedures to load, unload, and fire a specific firearm.

**muzzle:** The front end of the bore, where the projectiles leave the barrel.

**practical shooting:** A competitive shooting sport that was originally intended to simulate combat conditions but quickly strayed from its founders’ intent.

**primer:** The portion of a cartridge containing material that detonates on impact by the firing pin or striker, causing sparks to ignite the powder.

**prone:** A shooting position in which the shooter lies on his belly or partially rolled to one side.

**receiver:** The portion of the firearm to which the other components, such as the trigger mechanism, barrel, etc., attach.

## DEFENSIVE USE OF FIREARMS

**revolver:** A handgun whose action uses a rotating cylinder to align a series of new cartridges with the bore.

**rimfire:** A cartridge, such as the common .22, whose case contains the priming material in a folded rim, reducing the strength of the case to withstand the pressure from heavy powder charges.

**round:** An ambiguous term, sometimes used as a synonym for “cartridge” or “bullet.”

**shotgun:** A long gun with a smooth (unrifled) bore, designed primarily to launch multiple pellets of shot but that can also fire slugs (see below).

**shotgun slug:** A single projectile, similar to a bullet, designed to be fired through the smooth bore of a shotgun.

**single-action:** A trigger system that fires a firearm that has already been cocked, usually with a short, light trigger stroke.

**slide:** The upper part of most autoloading handguns that slides back and forth to eject the fired case and to load a new cartridge into the chamber.

**Smith, Clint:** A firearms instructor most recently known for his work at Thunder Ranch.

**softpoint:** A bullet whose copper-alloy “jacket” doesn’t extend all the way to the nose, leaving an exposed lead tip; such bullets will expand at rifle velocities but generally won’t expand at the velocities attained from handgun barrels.

**striker:** In American usage, this term is used for a firing pin that is driven solely by spring pressure, rather than being struck by a hammer.

**Sykes, Edward Anthony:** Coauthor of *Shooting to Live*, Sykes ended up in Wales in World War II, training British commandos and spies and American Rangers.

**top strap:** The portion of a revolver that forms the top of the “window” in which the cylinder rotates.

## GLOSSARY

**twist rate:** A measurement of the number of inches required for the rifling in a barrel to complete one full turn or twist, such as 1-in-10 inches.

**trigger guard:** A ringlike projection from the frame of a firearm that encircles the trigger to prevent snagging; on some autoloaders it may be more square than round.

**Weaver stance:** A two-handed shooting position in which the gun arm is usually slightly flexed and the nongun arm is flexed more sharply; popularized by the late Los Angeles Sheriff's Department deputy Jack Weaver.

**Williams, James:** An emergency physician in Wisconsin, Dr. Williams developed and teaches law-enforcement officers where to aim in a program called Tactical Anatomy.

